

Model 4000 and 4050 With Adjustable Brake

# Dynamatic

## Introduction

These instructions relate specifically to the following Model 4000 and 4050 controllers which are assembled for Speed Control with the Adjustable Brake modification.

Model 4000, 4.3 Amp Controllers:

- 15-533-1002 Panel Mount
- 15-535-1002 Standard Enclosure
- 15-536-1002 Blank Cover

Model 4050, 8 Amp Controllers:

- 15-539-0002 Panel Mount
- 15-540-0002 Standard Enclosure

Connection diagram, schematic diagram, switch programming, plug wiring connection, adjustment procedure and recommended spare parts list for these specific assemblies are contained in this instruction sheet. Any differences between these two controllers are clearly noted.

Use instruction manual IM-130006-83XX with this instruction sheet for complete installation, operation and maintenance instructions.

**CAUTION:** Above ground electrical potentials can be hazardous. Always disconnect electrical power before working on the controller.

\* Heat sink assembly, HS1, and its wiring apply only to the Model 4050 controllers. These parts are not supplied on Model 4000 controllers. The parts are mounted on the 15-530-5 main 4000 board.

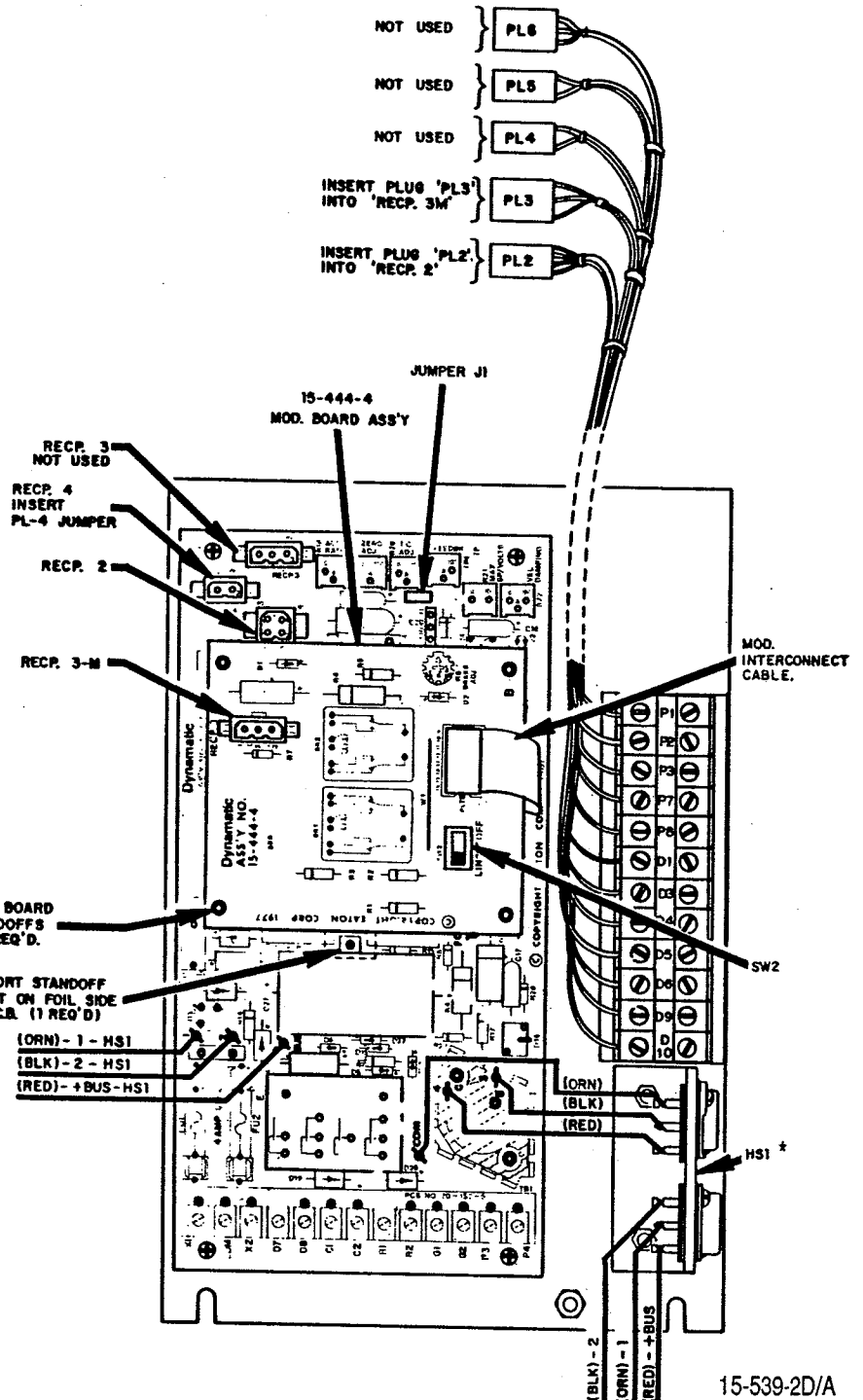

Model 4050 Controller Panel with Modification Board 15-444-4  
Adjustable Brake

**DRIVE SOURCE INTERNATIONAL INC.**

7900 Durand Avenue, P.O. Box 0361,  
Sturtevant, Wisconsin, U.S.A. 53177  
Tel.: 262.554.7977 • Fax: 262.554.7041  
Toll Free: 800.548.2169  
E-mail: drivesourceusa.com



# Connection Diagram for Standard Cast Enclosure 4000 Controller

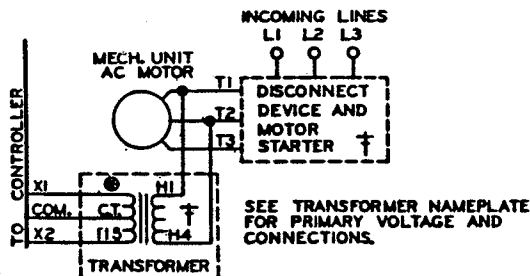
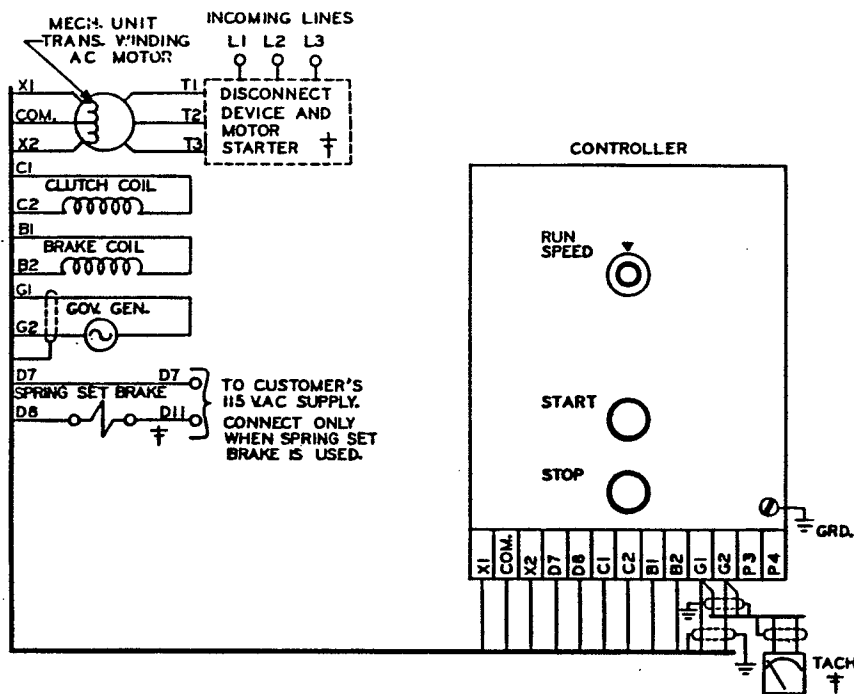

## CONTROL PROGRAMMING

15-530-5/6 P.C.B.

J1-POSITION-NORM.

15-444-4 P.C.B.

SW2- POSITION-LIN

TO ELIMINATE LINEAR ACCELERATION,  
PUT SW2 IN "OFF" POSITION

ED-58202/A

### Note 1:

This equipment must be installed in compliance with National Electrical code and all applicable state and local codes.

### Note 2:

Transformer may be supplied as a winding in the ac motor or as a separate item. Standard connections to winding in mechanical unit and to separate transformer are both shown above.

### Note 3:

Values shown are typical. See BOM for actual values.

- Programming and Mod. interconnect plug/recp.
- Operator's station and PCB interconnect plug/recp.
- Screw terminal
- ⚡ Signal common
- ⚡ Power common
- ‡ Items furnished only when specified

# Schematic Diagram for 4000 Controller

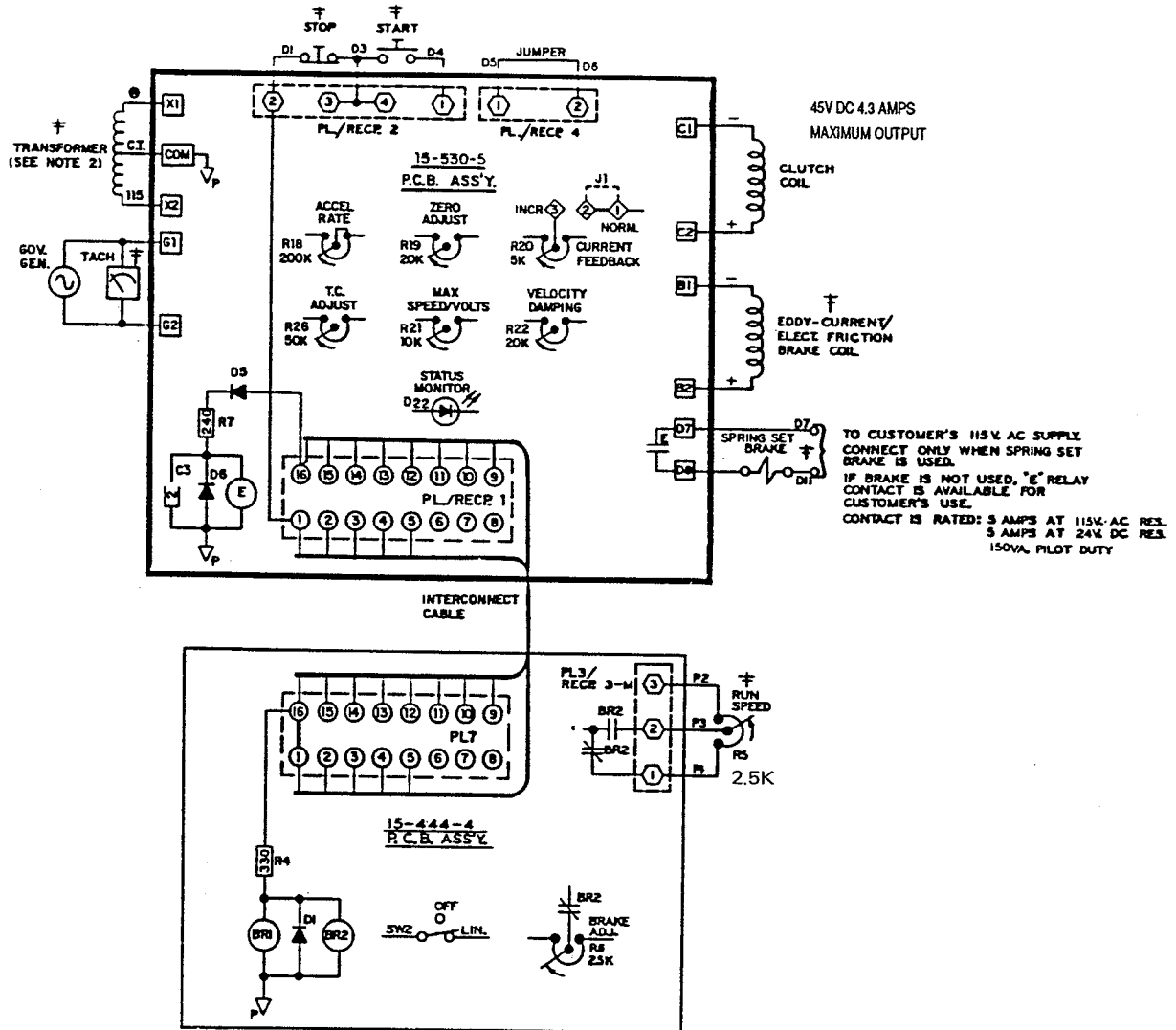

## Modification PCB Mounting

If you have purchased a complete controller this section may be passed over and you may proceed to General Description.

- Place the Main PCB in front of you with the long dimension in a horizontal position and the terminal strip to the left.
- Remove the DIP switch by pulling it straight out of the receptacle, RECP 1. Then, peel the adhesive-backed label off the other half of RECP 1.
- Insert the arrow-type locking head of the four nylon stand-offs supplied into the four 0.188" diameter holes in the main PCB and press in. The tabs will snap out to lock the stand-offs permanently in position.
- Hold the modification PCB assembly over the stand-offs with the ribbon connector toward you and insert the ribbon connector plug into RECP 1. Be careful to see that all 16 pins are started properly into the receptacle before pressing the plug in.
- Align the holes in the modification PCB assembly over the stand-offs and press over the tapered posts until the locking flanges snap out to lock the board in position.

# Connection Diagram for 4000 Panel Mount/Blank Cover and 4050 Controllers

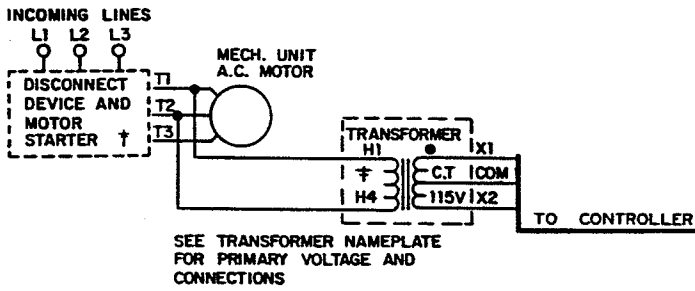
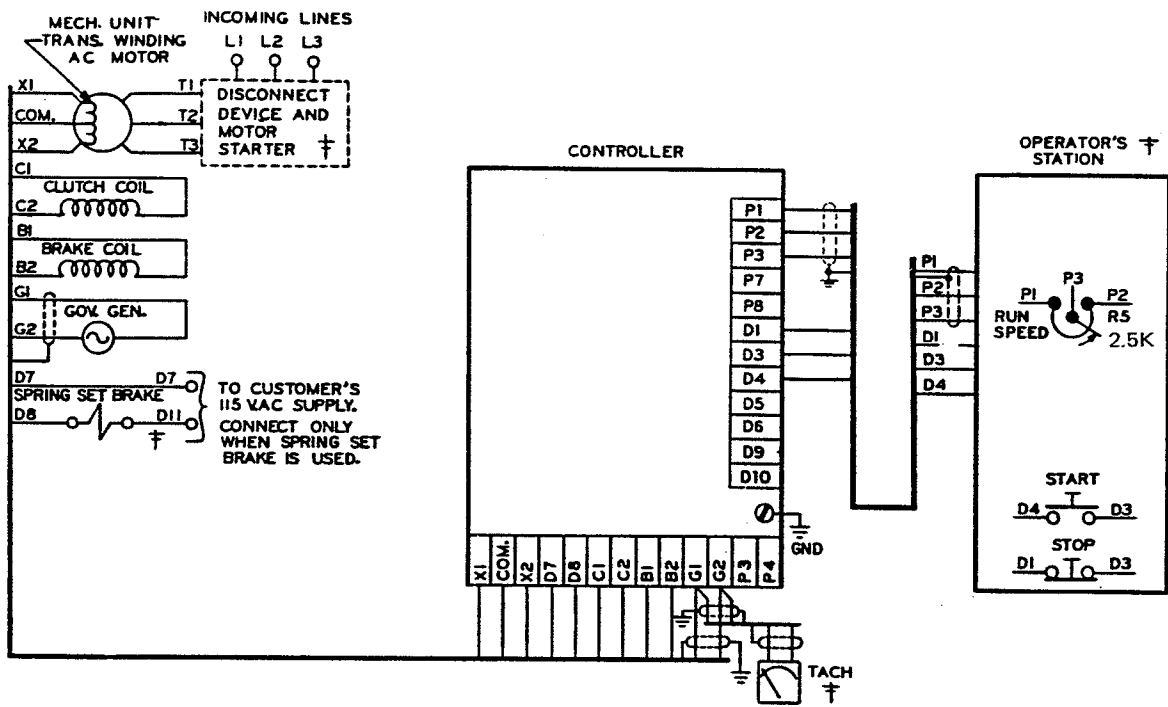

### CONTROL PROGRAMING

15-530-5/6 P.C.B.

J1- POSITION-NORM.

15-444-4 P.C.B.

SW2- POSITION-LIN

TO ELIMINATE LINEAR ACCELERATION,  
PUT SW2 IN "OFF" POSITION

See page 2 for notes and description of symbols.

ED-56802/-

# Schematic Diagram for 4050 Controller

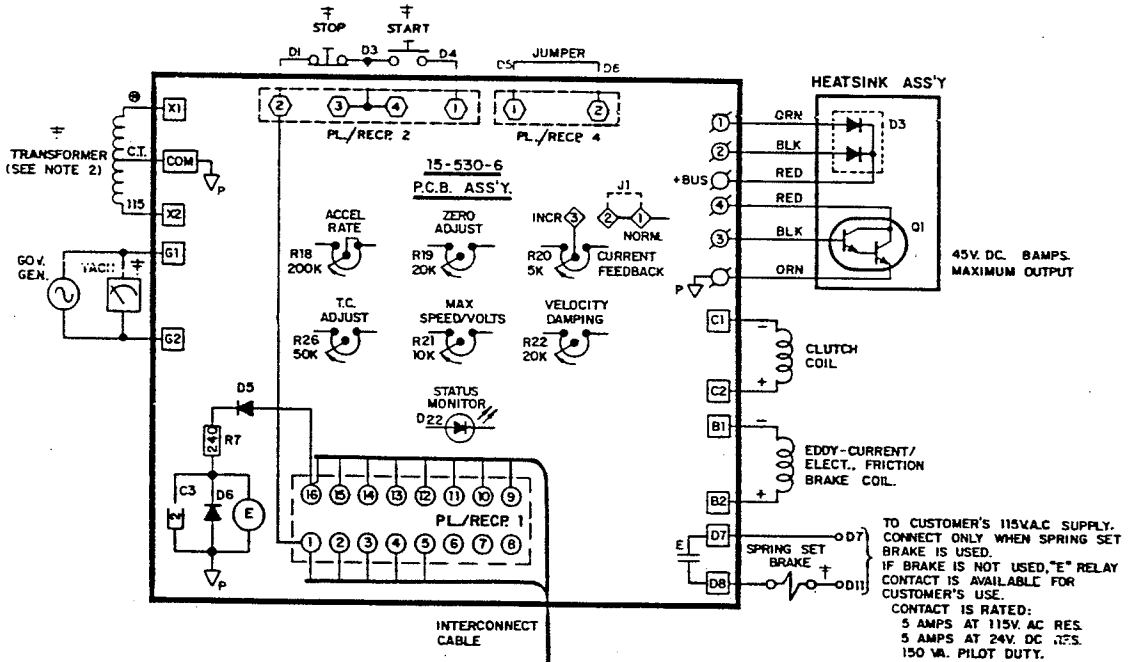

TO CUSTOMER'S 115VAC SUPPLY. CONNECT ONLY WHEN SPRING SET BRAKE IS USED. IF BRAKE IS NOT USED, "E" RELAY CONTACT IS AVAILABLE FOR CUSTOMER'S USE. CONTACT IS RATED: 5 AMPS AT 115V AC RES. 5 AMPS AT 24V DC RES. 150 W. PILOT DUTY.

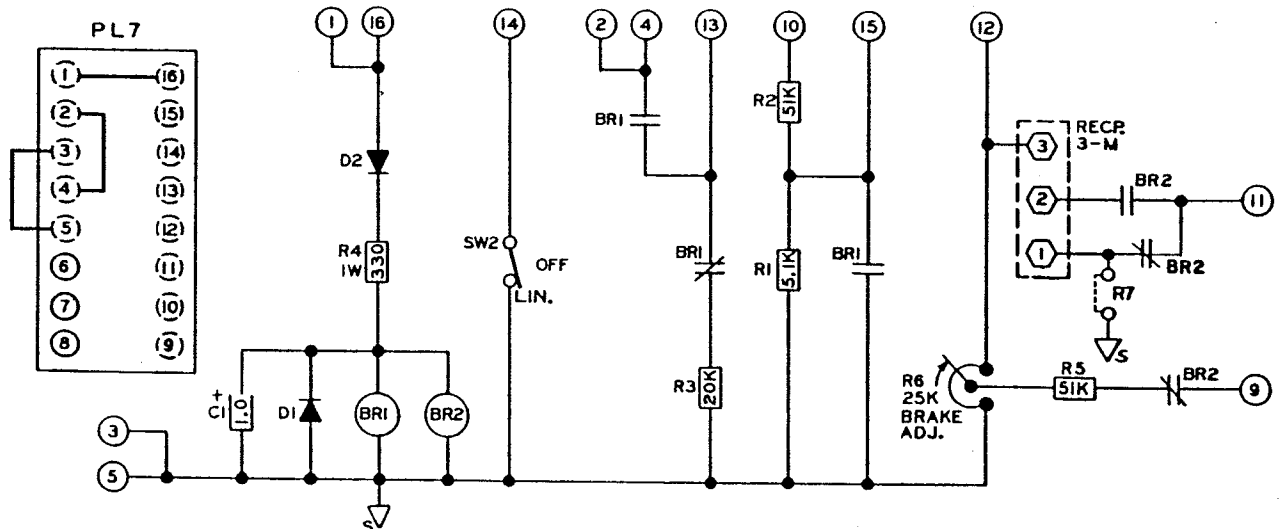
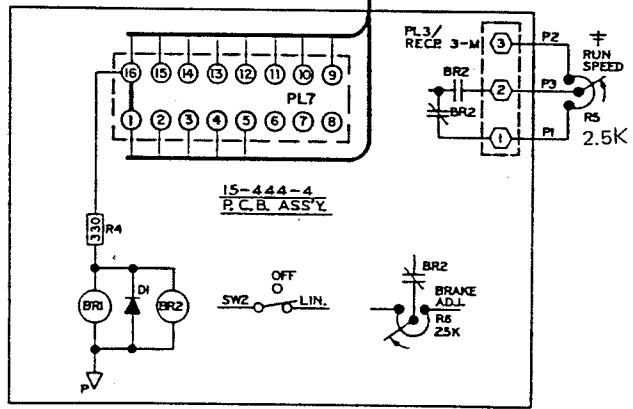

Adjustable Brake Modification PCB 15-444-4

## General Description

Some applications require a certain drive output deceleration. The deceleration is a function of braking torque and brake coil excitation. This modification circuit in conjunction with the main PCB provides a means of adjusting the brake coil voltage.

The brake reference potentiometer is located on the modification PCB. The speed reference potentiometer is connected to the modification by means of a "plug in" connector. All connectors between the modification and main PCB are made with a "ribbon cable" connector.

## Visual Inspection

1. Before proceeding to the preliminary adjustments, check the controller for any damage that may have occurred during shipment, such as loose connections and damaged wire or components.
2. Check all interconnecting wires for conformance to connection diagram and schematic as supplied in this instruction sheet.
3. Check the Operator's controls (which are supplied by customer) to see if they are connected properly per the connection diagram. This includes the Run Speed pot R5 and the Start and Stop pushbutton controls.

## Preliminary Adjustments

Perform the following preliminary adjustments (with no power applied to the controller).

1. Operator Controls (supplied by customer unless specified)
  - a. Set the Run Speed potentiometer R5 to 0% (Full CCW).
  - b. Note location of Start and Stop pushbuttons.
2. Main PCB 15-530-5 or 15-530-6

The pots used are screwdriver adjust,

single turn pots. Do not use a screwdriver with a blade width exceeding 1/8 inch.

- a. Set the Accel Rate potentiometer R18 to 100% (Full CW).
- b. Set the Zero Adjust potentiometer R19 to 0% (Full CCW).
- c. Set the Max Speed/Volts potentiometer R21 to 0% (Full CCW).
- d. Set the Velocity Damping potentiometer R22 as follows (see trimpot illustration):

Mechanical Unit Model Numbers		Velocity Damping Setting
AC/ACM/ACS/PD/VT Fractional Hp (FHP)	AS/AT/AE/VT/EC	
Fractional Hp	14/112/140	0%
181/182/184/186	18/21/132/160/180/210	50%
214/216/254/256	25/27/180/225/250/280	75%
280/320/360/440	320/360/440	75%

- e. Set the Time Constant (TC) Adjust potentiometer R26 as follows (see trimpot illustration):

Mechanical Unit Model Numbers		TC Adjust Setting
AC/ACM/ACS/PD/VT Fractional Hp (FHP)	AS/AT/AE/VT/EC	
FHP/181/182		0%
184/186/214	14/18/112/132/140/180	15%
216/254/256/280	21/160/210	30%
320/360/440	25/27/180/225/250/280	100%
	320/360/440	100%

\*Typical product number stamped on mechanical unit nameplate:

- 1) A1-100214-0053, specific mechanical model is AC-214.
- 2) B2-100210-0008, specific mechanical model is AS-21.

- f. Set the Current Feedback potentiometer R20 to 0% (Full CCW).

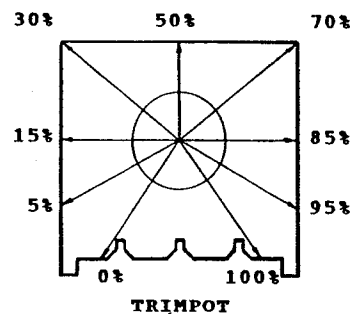

TRIMPOT ILLUSTRATION

3. Adjustable Brake Mod PCB 15-444-4

- a. Set the Brake Adjust potentiometer R6 to 25% CW.
- b. Set the Linear Accel switch SW2 in the Linear position if Linear Accel is desired.

Adjustment Procedure

CAUTION: To avoid personal injury or damage to the test equipment remove power before connecting or disconnecting test equipment.

The Model 4000 and 4050 controllers contain an LED status monitor which provides a visual means of setting the maximum speed and minimum bias. This LED set up along with an alternate method is given below.

1. Turn ON the power to the drive and start the ac motor.
2. Start the controller with the Start pushbutton. Note the location of the Stop pushbutton.
3. ZERO ADJUST R19 with LED monitor - Slowly increase the Zero Adjust Potentiometer R19 CW while monitoring the LED, D22. When controller output is turned ON or clutch voltage is turned ON (or the drive shaft begins to rotate), the LED should start flashing. Now just back off slowly until the flashing stops.

ZERO ADJUST R19, Alternate Method - This adjustment can be set to provide zero rpm or some minimum speed greater than zero, as required by the machine operating requirements.

- a. For zero rpm, turn the Zero Adjust potentiometer R19 CW until the output shaft just begins to turn. Then, back off on the control until the output shaft just stops turning. Stop and start the controller a few times to be sure the drive shaft does not rotate.

- b. For a minimum speed greater than zero, the LED cannot be used. Turn the Zero Adjust potentiometer CW until the desired speed is attained. For an accurate setting use a tachometer or stroboscope.

4. MAX SPEED/VOLTS R21 - This adjustment can be set to limit drive speed to its rated maximum or to a slower speed as required by the machine process. An LED status monitor has been provided on the main board to allow you to set the maximum speed without the use of a tachometer, stroboscope or voltmeter. However, an alternate method of set up using this equipment is given to set the maximum speed point. The tachometer or stroboscope will give an accurate rpm setting while the use of a voltmeter will give only an approximate speed setting. This is because the voltmeter is measuring generator voltage instead of actual output rpm.

MAX SPEED/VOLTS R21 with LED monitor  
Set the Run Speed potentiometer R5 at 100% (Full CW). The drive should be loaded for best results. Set the Max Speed/Volts potentiometer R21 at 100% (Full CW). CAUTION: drive will go to top speed. The LED should be out when the drive is at top speed. With the LED out, slowly turn the Max Speed/Volts potentiometer R21 CCW until the LED lights. This indicates that the speed of the drive is in the regulating range of the controller. The clutch voltage should drop below 45V. This will be approximately the maximum rated speed of the drive. The maximum speed point setting will vary with different mechanical units.

There are two other conditions for which the LED will be out besides the drive being set for zero speed, or running wide open above the regulating range. These are whenever the "E" relay is deenergized (the drive is stopped), or due to a wir-

ing error, ground or some malfunction of the controller itself.

MAX SPEED/VOLTS R21, Alternate Methods

- a. To set maximum rated speed with a tach or stroboscope: turn the Run Speed potentiometer R5 to 100% (Full CW). Allow the drive to accelerate to full speed, turn the Max Speed/Volts pot CW until the rated speed indicated is the same as the speed listed on the nameplate of the mechanical unit.
  - b. To set approximate maximum speed with a voltmeter, connect a voltmeter (60 Vac scale) across terminals G1 and G2. Turn the Run Speed pot R5 to 100% (Full CW). Allow the drive to accelerate to full speed. With the drive at full speed, turn the Max Speed/Volts pot CW until the meter reading ceases to rise. Back off the adjustment (CCW) until the meter reading just begins to drop. This is the point of maximum speed.
  - c. To set a maximum speed that is less than rated maximum speed requires the use of a tachometer or stroboscope indicator. This cannot be accomplished with the LED status monitor. Turn the Run Speed potentiometer to 100% (Full CW). Allow the drive to accelerate to full speed. With the drive at full speed, slowly increase Max Speed/Volts potentiometer setting CW until the desired speed is indicated.
5. Since there may be some interaction between the Zero Adjust and the Max Speed/Volts, particularly if the minimum speed is other than zero, repeat steps 3 and 4 until the desired speeds are obtained for both the zero and max positions of the Run Speed pot.

6. TIME CONSTANT (TC) ADJUST R26 - The TC Adjust is used to set current feedback by using coil voltage and a variable RC combination to simulate the different coil time constants of various size drives. A trimpot illustration is provided to facilitate the setting of this control. Sufficient range has been provided for drive sizes from fractional through 20 hp for the 4000 controller and up to 125 hp for the 4050 controller. Set your TC control appropriately for your individual drive size, as shown in Preliminary Adjustments.

Settings are not critical and so may be "tuned" for each drive. High inertia applications can benefit from a higher than normal setting.

7. CURRENT FEEDBACK R20\* - Normal operation will not require use of this potentiometer. Certain applications are best met with a negative current feedback response which is slower in settling and less likely to overshoot at low rpm's. There are some low inertia, light load, linear acceleration applications that may also benefit from improved low end linearity with current feedback damping. If you have one of these applications, remove Jumper J1 from the Normal position and place it in the Increased position. Adjust Current Feedback R20 as required to obtain desired drive response.
8. ACCEL RATE R18 - The purpose of Linear Acceleration is to slow down drive response to an increase in command. Without Linear Accel control, the drive will respond to operator speed adjustments very quickly, limited only by the torque capacity of the drive. With the Linear Accel circuit, the output of the controller is linear with respect to time. This circuit is adjustable from 3 to 90 seconds. When set at the slowest acceleration rate, the drive will take 90 seconds to accelerate from zero to rated



speed, following a linear ramp. When less than rated speed is set, this time required to reach top speed is proportionally less.

The Linear Acceleration circuit may be activated or deactivated in the Run mode by setting the programming switches as indicated on the programming chart on the connection diagram.

To set the Accel Rate: stop the controller with the Stop pushbutton. Turn the Run Speed potentiometer to 100% (Full CW). With the drive at a complete stop, push the Start pushbutton and time the interval required for the drive to accelerate from zero to full speed. Adjust the Accel Rate potentiometer R18 CCW for a slower accel rate, or CW for a faster accel rate.

NOTE:

Only the Acceleration Rate is adjustable. The response of the controller to a reduced command is instantaneous. The response of the drive to a decrease in command is a function of drive system load and inertia.

9. VELOCITY DAMPING R22\* - This potentiometer is used to match the con-

troller response to the drive response (drive response is a function of the clutch coil time constant and system inertia). The proper setting for this adjustment depends on the drive size and total load inertia. See Preliminary Adjustments. If instability (speed control becomes erratic) occurs at any setting increase (turn CW) slightly until speed becomes stable.

\*See basic 4000/4050 manual for a more detailed description of this adjustment.

10. BRAKE ADJUST R6 (mod board) - This adjustment is used to obtain the desired braking action on the drive. With the drive running, push the Stop pushbutton and observe the brake action. Turn the pot CW from the preset position to increase braking torque and shorten stopping time, or CCW to reduce braking torque and increase stopping time.
11. Check motor current to make sure the motor is operating within its rating. If motor current exceeds the nameplate rating, shut it down and correct the problem. This completes the adjustment procedure.

Renewal Parts List for Standard 4000 and 4050 Controllers with Adjustable Braking

Qty	Part Number	Description	Legend
MODEL 4000 CONTROLLERS			
<b>15-530-0005 MAIN PCB ASSEMBLY**</b>			
1	27-123-0001	Mini-jumper	J1
* 2	32-018-4091	Fuse, 4 Amp, 250 V	FU1,2
* 1	53-398-0001	Relay, 4pdt, plug-in	E
<b>15-533-1002 PANEL MOUNT</b>			
1	15-530-0005	Main PCB (Refer to PCB parts list above.)	
* 1	15-444-0004	Adjustable Brake PCB assembly	
4	36-298-0010	Circuit board support	
<b>15-535-1002 STANDARD ENCLOSURE</b>			
1	15-530-0005	Main PCB (Refer to PCB parts list above.)	
* 1	15-444-0004	Adjustable Brake PCB assembly	
1	15-531-1001	Base assembly	
1	15-532-0001	Cover assembly	
* 1	15-529-0001	Pushbutton assembly	PB1,2
* 1	15-529-0003	Speed pot	R5
4	36-298-0010	Circuit board support	
<b>15-536-1002 BLANK COVER</b>			
1	15-530-0005	Main PCB (Refer to PCB parts list above.)	
* 1	15-444-0004	Adjustable Brake PCB assembly	
1	15-531-1001	Base assembly	
1	15-532-0000	Cover assembly (blank)	
4	36-298-0010	Circuit board support	

MODEL 4050 CONTROLLERS

<b>15-530-0006 MAIN PCB ASSEMBLY**</b>			
1	27-123-0001	Mini-jumper	J1
* 2	32-028-0100	Fuse, 10 Amp, 250 V	FU1,2
* 1	53-398-0001	Relay, 4pdt, plug-in	E
<b>15-539-0002 PANEL MOUNT</b>			
1	15-530-0006	Main PCB (Refer to PCB parts list above.)	
* 1	15-444-0004	Adjustable Brake PCB assembly	
1	15-529-0019	Heat sink assembly, incl. Q1 & D3	
4	36-298-0010	Circuit board support	
<b>15-540-0002 STANDARD ENCLOSURE</b>			
1	15-539-0002	Panel assembly (Refer to Panel Mount parts list above.)	

\* denotes minimum spare parts.

\*\* denotes suggested spares when downtime is critical.

