

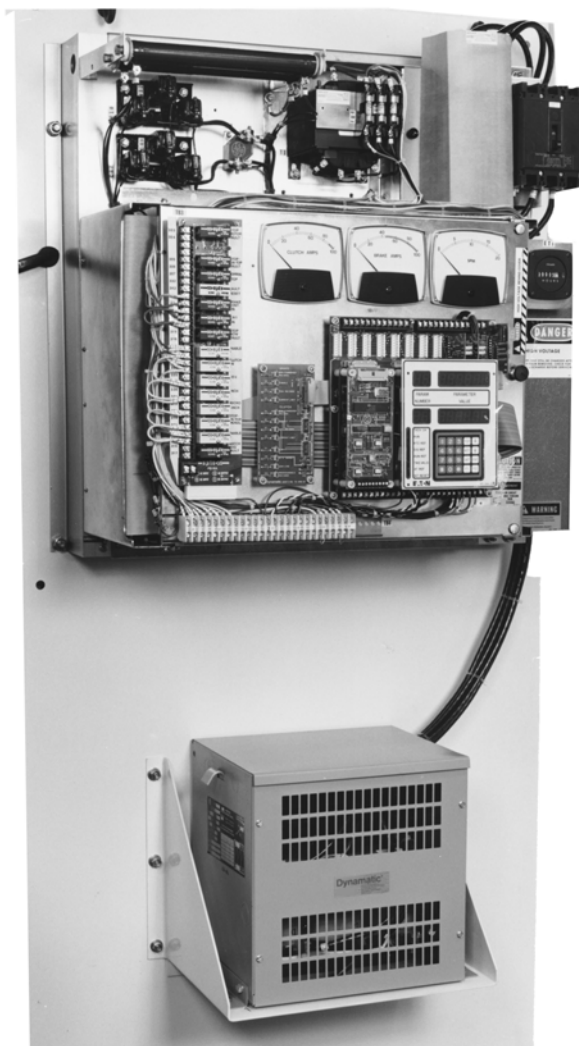

## C.E.S. Stamping Press Controller

### INSTRUCTION MANUAL

(Revised 07/04)



#### **DRIVE SOURCE INTERNATIONAL INC.**

7900 Durand Avenue, P.O. Box 0361

Sturtevant, WI USA 53177

Toll Free: (800) 548-2169

Phone: (262) 554-7977 - Fax: (262) 554- 7041

Email: [sales@drivesourceusa.com](mailto:sales@drivesourceusa.com)

24 Hours Service: (262) 499-0437

Application Engineering ✧ Quality Products ✧ Total Solution

**DANGER HIGH VOLTAGE**

Motor control equipment and controllers are connected to hazardous line voltage. When servicing drives and electronic controllers, there may be exposed components with their cases and protrusions at or above line potential. Extreme care should be taken to protect against shock. Stand on an insulating pad and make it a habit to use only one hand when checking Components. Always work with another person In case an emergency occurs. Disconnect power whenever possible to check controllers or to perform maintenance. Be sure equipment is properly grounded. Wear safety glasses whenever working on an electronic controller or electrical rotating equipment.

**CAUTION**

Rotating shafts and above ground electrical potentials can be hazardous. Therefore, it is strongly recommended that all electrical work conform to National Electrical Codes and local regulations. Installation, alignment and maintenance should be performed only by qualified personnel.

Factory recommended test procedures, included in the instruction manual, should be followed. Always disconnect electrical power before working on the unit

REFER TO OSHA RULES AND REGULATIONS. PARAGRAPH 1910.219 FOR GUARDS ON MECHANICAL POWER TRANSMISSION APPARATUS.

**NOTE:**

Since improvements are continually being made to available equipment, the enclosed data is subject to change without notice. Any drawings are for reference only, unless certified. For additional information contact your nearest Eddy Current Representative listed in the Yellow pages under "Power Transmission Equipment". Or you can call DSI/Dynamatic® at 1-800/548-2169.

**IMPORTANT NOTICE**

The printed contents in this manual are to be used for reference only. Due to periodic engineering design changes and the addition of modifications, this material is provided as a guide only.

Refer to engineering drawings for your specific unit. If you do not have your units engineered drawings, please contact the publications department at the factory.

For additional information regarding contents, direct your request to one of the following areas:

Instruction Material	Sales/Marketing
Technical/Operational Questions	Engineering
Parts/Order Inquiry	Customer Service

This notice is provided to clarify the Intent of the instruction book contents and to inform our customers how to obtain appropriate technical assistance from the proper source.

## TABLE OF CONTENTS

	Page No.
<b>SECTION 1 - GENERAL INFORMATION</b>	
Introduction	5
Safety	5
Training	5
Receiving and Damage Claims	5
Warranty	5
Handling	5
Storage	6
Long Term Storage	6
Removing from Storage	6
Electrical Part Numbering System	6
Category Number and Description	6
Symbols Used in Illustrations	8
<b>SECTION 2 - GENERAL DESCRIPTION</b>	
Construction	9
CES Controller	9
Specifications	9
Power Circuitry	9
Keypad Programming	10
Field Adjustments	10
Light Emitting Diode (LED) Indicators	10
Press Speed Control	10
Angle Measurement	10
CES Digital Master Regulator (DMR)	11
Press Control Interface - Commands Accepted	12
Press Control Interface - Output Signals	13
Press Control Interface – Serial	14
Signals for Customer's Recorder	14
Analog Meters	14
Brake Contactor	14
Press Operating Modes	14
Press Control Parameters	20
<b>SECTION 3 - OPERATION</b>	
Purpose	22
Constant Energy System	22
Stamping Press Operation	22
Eddy-Current Clutch and Brake	22
Variable Speed Press Drives	22
Power Amplifier	23
CES Logic Board	24
Logic Power Supply Inputs	24
Logic Control Lines	24
LEM Current Feedback Amplifiers	24
Fault Priority Encoder	24
Fault Codes	24
CES Controller Parameters	25
Keypad Programming	26
Optional Features	28
<b>SECTION 4 - START-UP AND ADJUSTMENT</b>	
Power Conversion	31
Press Speed Control	31
Angle Measuring and Control Circuitry	31
Start-Up Procedure	31
Approximate Parameter Settings	34
<b>SECTION 5 - MAINTENANCE AND TROUBLESHOOTING</b>	
Maintenance	36
Troubleshooting	36
Renewal Parts, and Service	37
List of Spare Parts Common to All CES/DR Controls	38
List of Spare Parts Unique to Controllers as Indicated	38

## GENERAL INFORMATION

### **INTRODUCTION**

This instruction manual relates specifically to the CES Stamping Press Controller. Instructions are in sequence beginning with General Information and proceeding through Receiving, Operation, Start-up and Maintenance and renewal parts information.

Please be sure that you have your units board schematics and connection diagrams, if you do not have these drawings, contact the Publications Department at the factory and request the drawing numbers by providing the model number and serial number on the nameplate of your unit. Items on your drawings supersede any items listed or referred to in this manual. Please note that there may be charges incurred for replacement manuals and/or drawings.

If you have any questions regarding this controller contact the DSI/Dynamatic. DSI/Dynamatic has distributors located throughout the United States and in various other countries. If you do not know who your distributor is, please call the factory at 1-800/548-2169, fax 1-800/828-5072, E-mail: sales@drivesourceusa.com, Web site: www.drivesourceusa.com

### **SAFETY**

With any electronic equipment or rotating electric machinery, potential safety hazards are present and require safeguards and proper use. This equipment must be installed properly, using safe procedures, and meet the requirements of all applicable safety codes. The wiring must be in accordance with the National Electrical Code and all other local codes and regulations. Shaft guards as well as protection for operating and maintenance personnel against high voltage and moving machine parts is essential. Refer to OSHA rules and regulations, paragraph 1910.219, for guards on mechanical power transmission apparatus. Please heed these safety instructions.

DANGER, WARNING, CAUTION and special INSTRUCTION labels are applied to the equipment to remind you of the hazards that exist. Know your equipment before handling or working on it.

DANGER - is used where an immediate hazard exists. Failure to follow instructions could be fatal.

WARNING - means a possibility of injury to personnel, but not as severe as a Danger Warning.

CAUTION - is used to warn of potential hazards and unsafe practices.

INSTRUCTION labels and notes are used when there is a need for special instructions related to safety, proper operation or maintenance.

### **TRAINING**

Training programs are an essential part of safe and correct operation. Training provides the knowledge necessary to obtain top performance from your equipment. DSI/Dynamatic recognizes this fact and conducts training schools to educate your plant personnel in safe maintenance and operating procedures.

Training schools are held at company headquarters, in Kenosha, Wisconsin. There is a nominal charge for this service. If you are interested in scheduling a training school, please contact the Marketing Department for further information.

Special training schools structured around your specific equipment may also be arranged.

### **RECEIVING AND DAMAGE CLAIMS**

Your CES Stamping Press Controller has been operated and tested at the factory prior to shipment. Specific test procedures are followed to assure the quality of your controller. Carrier approved packing methods assure safe shipment to your plant. Shipment is made F.O.B. our factory, with the carrier assuming responsibility for your unit. Therefore, it is essential that you carefully inspect the shipment upon delivery to ensure that no damage or lost items have occurred in transit. Loss or damage is covered by the carrier, not by the product warranty. File a claim immediately with the carrier if any damage or loss is found. Should you require assistance in settling your claim with the carrier, contact our nearest sales office. You will need the unit model number, serial number and your purchase order number for identification.

### **WARRANTY**

Your new CES Stamping Press Controller is covered by a one-year warranty against any manufacturing defect in either material or workmanship. This warranty starts on the date of shipment to your plant. Should the controller fail within the one-year warranty period, contact the factory for a Repair Instruction (RI) form. Fill in all required information on the form and return the form with the controller to our Repair Service Department in Kenosha, WI for warranty repair. Freight charges both ways are your responsibility.

### **HANDLING**

The CES Stamping Press Controller weighs about 600 pounds. Do not drop or subject the controller to repeated shock or vibration. Do not stack heavy material on the controller. The printed circuit boards, components and electrical wiring may be easily damaged.

### **STORAGE**

Store electrical control equipment in a clean, dry location with a non-corrosive atmosphere, protected from sudden temperature changes, high levels of moisture, shock and

vibration. Electrical components are delicate and easily damaged - provide adequate protection for them.

Ambient temperature should not exceed 25°C. (77°F.) on a continuous basis or 40°C. (104°F.) on an intermittent basis. The minimum temperature must remain above freezing and above the dew point of ambient air. High temperature, corrosive atmosphere and moisture are detrimental to electrical control equipment.

### LONG TERM STORAGE

The manufacturer's warranty covers repair or replacement of defective materials and rectification of faulty workmanship. It does not cover damage and deterioration transpired during storage period.

Some examples of deterioration due to storage are:

1. Corrosion of terminals and contacts.
2. Loss of capacitance of electrolytic capacitors.
3. Moisture absorption within insulation and composition resistors.

These are not manufacturer's defects and will not be covered by the warranty policy.

Refer questions to the Electrical Engineering Department in Sturtevant, Wisconsin.

### REMOVING FROM STORAGE

Before returning the controller to service after long-term storage, it will be necessary to carefully inspect it for any signs of damage or deterioration. Correct any deficiency. Carefully inspect the controller for signs of moisture, especially with respect to transformers and composition resistors. If moist, the autotransformer will require thorough drying.

Corrosion is an important factor. Inspect terminals, plugs, sockets and contacts for signs of corrosion. If detected, cleaning will be necessary.

Before applying power, make sure all connections are tight.

The suggested procedures given are only recommendations offered to aid our customers in preserving stored equipment. We cannot guarantee stored equipment, even if all procedures are followed; damage or deterioration may still occur. Equipment storage is not covered by warranty.

### ELECTRICAL PART NUMBERING SYSTEM

The numbering system for electrical component and assembly part numbers contains some useful data that could be of value to the technician working with or troubleshooting the controller. The number is twelve digits, arranged in a two-six-four digit sequence with the groups separated by dashes. As an example, one printed circuit board part number may be 15-000825-0001. This twelve-digit number is the complete number, as recognized by the computer. Frequently the number

is abbreviated by dropping zeros, i.e., 15-825-1. The number printed on the board and in the technical instruction material is the abbreviated form. However, the actual bill of material and order paper work for that board would use, the complete number 15-000825-0001.

### CATEGORY NUMBER AND DESCRIPTION (Reference first two digits and chart below)

14	Alarms
15	Assemblies
16	Bearings
17	Blocks
18	Blowers
19	Brackets
20	Cable
21	Cams & gears, cam switch assemblies
22	Cans
23	Capacitors
24	Chassis
25	Circuit breakers
26	Coils A coil assemblies
27	Connectors, plugs sockets
28	Control unit & parts
29	Counters
30	Dial plates & knobs
31	Enclosures
32	Fuses & fuse holders
33	Filters (radio interference)
34	Gaskets & gasket material
35	Generators
36	Hardware
37	Instruments
38	Insulators & Insulation
39	Lights & Fixtures
40	Motors
41	Motor starters & controls
44	Operator's panels
45	Panels
46	Phase Shifters
47	Photoelectric devices
48	Plates
49	Potentiometers
50	Power converters
51	Reactors
52	Regulators
53	Relays & contactors
54	Resistors
55	Semiconductors
56	Shock Mounting
57	Solenoids
58	Switches
59	Servo mechanisms
60	Terminals
61	Thermal devices-excluding motor starter heaters
62	Timers
63	Transducers
64	Transformers, chokes
65	Tube sockets
66	Valves
67	Wires
68	Wiring duct
69	Tubes

- 70 Insulated mounting boards
- 71 -
- 72 Master bill of material
- 73 Engineering data sheets
- 74 -
- 75 Reworked or exchanged assemblies

The middle six digits describe a basic type of part, such as physical or electrical characteristics of a group or family of parts. As an example, a resistor family of 1/2 watt carbon resistors have the number 000045. The part number of one specific resistor in this family is a 54-000045-0102.

The last four digits describe a specific part within the family and may be assigned in numerical sequence or may describe the specific part value. The following table lists those part categories where the last four digits have a significant meaning to the technician.

<u>Category</u>	<u>Part Name</u>	<u>Parameter Described</u>
23	Capacitor	Capacitance
32	Fuses	Ampere rating
49	Potentiometer	Resistance
54	Resistors	Resistance
55	Power diodes and SCR's	Peak reverse voltage

<u>Last 4 digits</u>	<u>Numeric Value</u>
2593	.025
2592	.25
2591	2.5
0250	25.
0251	250.
0252	2500.
0253	25000.

# Symbols Used in Illustrations

	N.C. PUSHBUTTON		RESISTOR, FIXED		OPERATIONAL AMPLIFIER
	N.O. PUSHBUTTON		POTENTIOMETER		SCREW TERMINAL CONNECTION
	RELAY, LETTER DENOTES SYMBOL		RHEOSTAT		PROGRAMMING AND MOD. INTERCONNECTION
	SELECTOR SWITCH		CAPACITOR		P.C.B. PUSH-ON CONNECTION
	FUSE		CAPACITOR, ELECTROLYTIC		COVER/P.C.B. INTERCONNECTION
	ANALOG INDICATOR		N.O. CONTACT		SIGNAL COMMON
	GOV. GEN.		N.C. CONTACT		POWER COMMON
	BRIDGE RECTIFIER		COIL OR TRANSFORMER WINDING		GROUND
	TEST POINT		DIODE OR RECTIFIER		ENCLOSURE COMMON
	WIRE ASS'Y. WITH PUSH-ON TERMINAL		ZENER DIODE		START OF TRANSFORMER WINDING
	SHIELDED CABLE		P.N.P. TRANSISTOR		CONDUCTORS CONNECTED
			N.P.N. TRANSISTOR		CONDUCTORS NOT CONNECTED
					ITEMS FURNISHED ONLY WHEN SPECIFIED

## CES STAMPING PRESS CONTROLLER DESCRIPTION

### CONSTRUCTION

The CES Stamping Press Controller is a solid state, closed loop velocity controller designed specifically for use with Dynamatic® eddy-current press drives. The controller is built with analog, digital and microprocessor circuitry. All components of the CES Controller are contained on a sub-panel, except for an autotransformer that is mounted separately. The panel measures 74" by 31.25". Special sizes are made to order upon request.

### CES CONTROLLER

The basic CES press drive controller has proven to be readily adaptable to synchronization (position) control. This system utilizes a position transducer (digital shaft encoder) to measure press position (crank angle) and compares this feedback information against a digital position reference. All information is handled in parallel digital form and has a minimum sample rate compatible with the system.

The difference between the reference and the feedback signal (position error) is translated to an analog signal in a D-A converter. The analog signal is sent to the press velocity control for final processing and power amplification for press drive control.

The CES controller is easily applied to single or multiple action presses where speed control is desirable. The system offers many unique features not available with other press drive designs for use on draw presses, banking presses, transfer presses and on synchronized presses with automated handling equipment. The combination of the eddy-current package press drive and the CES controller offers a simple, safe, low maintenance and reliable drive system to do a wide variety of the jobs required of modern production press equipment.

### Specifications

Mechanical Unit	49 -		37 -		
	63	42	42	32	21
Input Current Aac Max	137	91	72	54	35
Input Current Aac Average	98	65	53	40	26
Clutch Current ADC	180	120	96	72	48
Brake Current ADC	90	60	48	48	24

Retrofit control for existing presses have different specifications from those listed here. Check your specific unit or contact the factory.

- Input Voltage: 480 VAC, +10%, -15%, 60Hz
- Output Voltage: 850 VDC Field Forcing
- Clutch Duty Cycle: 70%
- Brake Duty Cycle: 30%

### POWER CIRCUITRY

The incoming three phase 480 VAC connects directly to the circuit breaker or terminal block at the top of the panel. 120 VAC power for control circuitry, I/O modules and the power supply board is provided by transformer T1. Fuses FU5 and FU6 protect T1 against short circuits and internal grounds. Capacitors C3, C4 and C5, along with the impedance of the autotransformer, serve to filter the incoming power to prevent line noise from affecting the controller and to reduce line disturbances by the controller. The autotransformer steps up the line voltage from 480 VAC to 600 VAC. FU1, FU2 and FU3 are fast acting semiconductor fuses sized to prevent damage to the SCR's in the event of an output short circuit. All three incoming lines are sensed at the clutch gate driver board and fed back to the logic board for proper gate signal synchronization, and ultimately to the DMR (Digital Master Regulator) for the purpose of ensuring safe limits. The line voltage may be read on the DMR display to be discussed later.

Separate contactors for the brake and clutch sections provide positive mechanical disconnects from the input power. Each section consists of a full converter composed of six SCR's capable of forcing the 300 VDC rated coils to a peak value of 850 VDC, as well as causing current flow to cease by inverting or by applying a negative 850 VDC to the coils. Separate brake and clutch gate driver boards supply the gate signals to the appropriate SCR's; they are located on the left side bracket. Each SCR has di/dt protection from a series choke and dv/dt protection from snubber networks located on the circuit boards, which consist of series resistors, capacitors and diodes connected in parallel with the SCR. Also across each SCR is a Metal Oxide Varistor (MOV) for transient voltage protection.

A minimum resistive, or latching, load is provided with a power resistor across each dc bus, identified as C1-C2 and B1-B2. Each bus also has an MOV suppressor to clamp any high voltages arising due to the inductance of the coil loads and to provide a current path for the short period of time between interruption of current (such as a contactor opening), and the establishment of current flow in the C phase SCR's by the free wheel gates. Clutch and brake voltages are fed back to the logic board through the brake gate driver board. The output leads are routed through L1 and L2, which are isolated current feedback sensors with the current signals going directly to the logic board. The output leads terminate inside and near the bottom of the logic door.

The CES stamping press controller provides control for the full range of Dynamatic® eddy-current press drives. The power conversion circuitry operates from 480 VAC input and provides a maximum of 850 VDC coil excitation voltage.



Clutch excitation provides up to 180 Amps peak at 70% duty cycle. Brake excitation provides up to 90 Amps peak at 30% duty cycle.

**KEYPAD PROGRAMMING**

The keypad is mounted integrally with the DMR. It is connected to the main DMR through a ribbon cable and is used for viewing and modifying various parameters within the system. The module consists of the following: a sealed 20-button, dome-contact type keypad; two independent sets of 8-digit, 7-segment LED displays; and a row of 8 individual status LED's. The keypad can accept the following entries: numbers 0 through 9. Top, Bot, up arrow, down arrow, \*, #, Ent, F1 & F2. Dat is a non-functional key. All of the operating modes that are included on the keypad programmer are shown in Figure 2-1. Each mode includes an LED to indicate when it is in operation. For information on how to use the keypad, refer to Operation, Section 3.

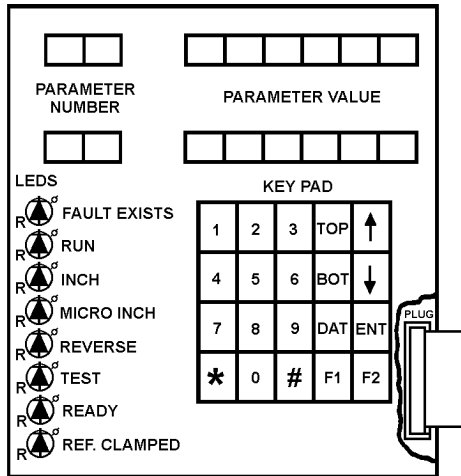

**KEYPAD PROGRAMMER**      **FIGURE 2-1**

**FIELD ADJUSTMENTS**

Some operator control adjustments can be made in the field. Potentiometer R116 on the power supply can be adjusted for +5 volts. Six adjustments can be made on the main logic PCB (15-822-\*) as follows: Clutch Velocity Damping, Clutch Current Damping, Clutch Current Limit, Brake Velocity Damping, Brake Current Damping and Brake Current Limit. These adjustments are explained in Section 4.

**LIGHT EMITTING DIODE (LED) INDICATORS**

In addition to the LED noted for the keypad programmer, LED indicator lights are also located on the printed circuit boards where operating circuit conditions need to be known. The printed circuit boards that have LED's are described below.

LOGIC INTERFACE INDICATOR PCB (15-242-57): Refer to Figure 2-2 for the identification of the LEDs found on this printed circuit board.

CLUTCH GATE DRIVER (15-565-27) AND BRAKE GATE DRIVER (15-565-28) PCBs: Each LED represents a phase that is firing when it is on. Refer to Figure 2-3, for the identification of the LEDs found on these printed circuit boards.

I/O PCB (15-6502-3001): Refer to Figure 2-4 for the identification of the LEDs found on this printed circuit board.

**PRESS SPEED CONTROL**

The press control provides a closed loop speed control operation with inner current loops on both the clutch and brake. It provides adjustable acceleration and deceleration. The reference data is modified by a press angle measuring and control circuit that changes the reference profile at adjustable angles, as shown in Figure 2-5.

**ANGLE MEASUREMENT**

The press control provides a means of measuring press angles by utilizing a position resolver mounted on the output gearing of the press drive. The position information is then used to set a reference profile based on stored data of up to 6 angles and 6 predetermined speeds. Details are further described under "CES Digital Master Regulator (DMR)" and "Press Operating Modes."

**LOGIC INTERFACE PCB INDICATORS**

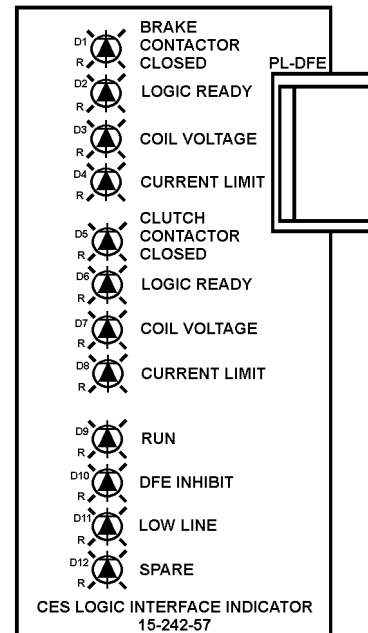

**FIGURE 2-2**

### CES DIGITAL MASTER REGULATOR (DMR)

The DMR Controller is a microprocessor based solid state electronic control system operating in conjunction with a CES press drive controller. It provides the interface with the press manufacturer's control. It also provides the safety circuits necessary to ensure proper

operation of the CES controller. Parameters are scaled in user units when applicable.

Upon power-up in the field, the values will be set by the factory. Some of these values will undoubtedly require modification before the press will function properly. The keypad must first be unlocked using the proper password before these parameters may be changed. See the instruction sheet for your particular EPROM to learn how to unlock the keypad. The operator must next present all of the operator alterable parameters from the keypad programmer and/or they must be downloaded from the serial interface. Once these values are set, they are retained and need not be reentered unless the values are to be changed or a new factory-programmed NVRAM is installed. The NVRAM memory chip has a battery internal to the chip that saves the information stored in the memory during the powering down situations of the control. This battery has a ten-year life. However, the battery is only called upon to function during periods where there is no power applied to the control. Therefore, the life of the battery may greatly exceed the ten-year period if there are no extensive periods where the control is actually turned off. Once the parameter values have been set, the system may be run by activating the appropriate signals in the control circuitry.

High voltage input and output signals for the microprocessor are handled through optically isolated solid state relay modules, which are mounted on an auxiliary relay mounting rack. All 120 VAC control signals are converted to 5 volt TTL-logic levels, which interface with the DMR. There are status LED's located next to each relay on the mounting rack. These LEDs light up to indicate active (closed contact) inputs and outputs. Refer to the electrical diagrams for the various control functions passing through this relay mounting rack.

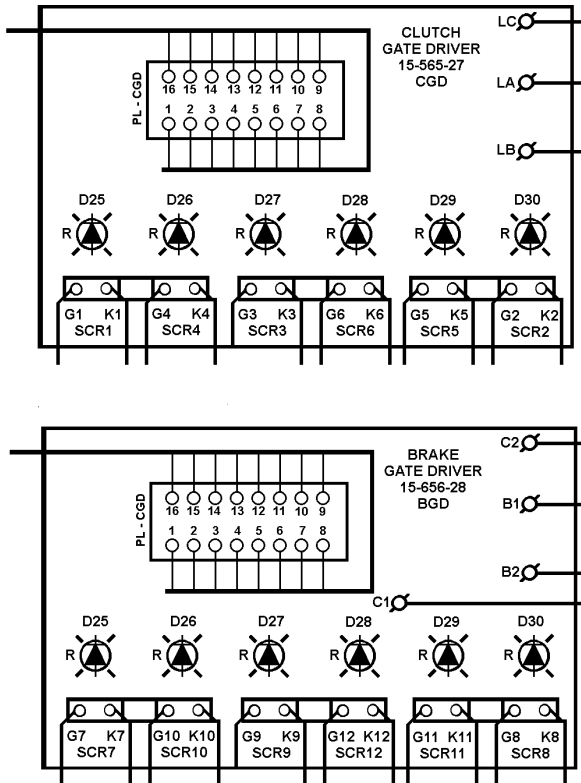

**CLUTCH AND BRAKE GATE DRIVER PCB INDICATORS** **FIGURE 2-3**

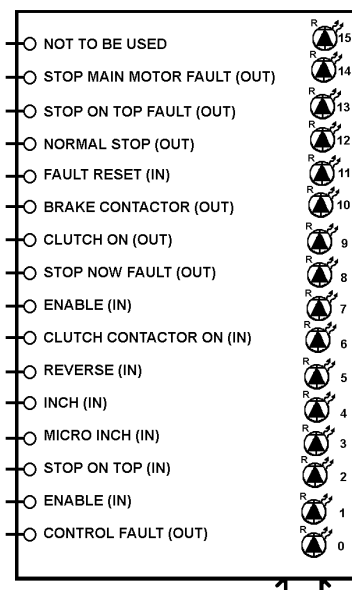

#### DURING NORMAL OPERATION

- 15 --
- 14 ON
- 13 ON
- 12 ON
- 11 OFF
- 10 ON
- 9 ON
- 8 ON
- 7 ON
- 6 ON
- 5 OFF
- 4 OFF
- 3 OFF
- 2 OFF
- 1 ON
- 0 ON

**I/O PCB INDICATORS** **FIGURE 2-4**

#### DMR Assemblies

Part Number	Function
15-779-11	Keypad Display
15-779-113, or -112	Resolver Interface
15-575-20	Main Controller PCB
15-814-3	Serial Interface
15-814-108	Dual D/A
15-775-2	First Fault Indicator

#### DMR Scaling PCBs

Part Number	Function
15-869-1	Ac Line Voltage (in)
15-869-1	Brake Current Feedback (in)
15-869-1	Clutch Current Feedback (in)
15-869-2	Manual Run Speed (in)
15-869-100	Speed Feedback (output)

The typical DMR, part number 15-820-33 to 37, consists of the assemblies listed in Table 2-1 and the analog scaling printed circuit boards listed in Table 2-2. The

numbers for a specific control may vary, see your Control Data Master.

### PRESS CONTROL INTERFACE - COMMANDS ACCEPTED

The CES controller will accept nine different input command signals from the press controller that are available for the operator to make, They are as follows: two Enables, Clutch Contactor ON, Inch, Micro Inch, Reverse, Control Power ON, Stop-On-Top and Fault Reset. Some controls also have a Stop-on-bottom command.

#### ENABLE:

The enable signals are required to start the drive. These contacts are the last contact closures in the start sequence. The clutch contactor ON signal and the two enable signals must all be given within 170 ms of one another or a fault will be created. The enable contacts must be closed in order to run. Upon opening either of these contacts, the press control signals the CES controller to stop the drive immediately with a command to zero speed and to open the clutch contactor 450 milliseconds later. The CES controller responds to this removal of enable with a normal stop signal. The enable contact closures must be given only after all safety features of press operation have been determined to be in a "GO" status by the press control. The release of the friction brake through the air pressure switch and/or the limit switch showing friction brake travel is sometimes used as the last event in the chain of events that provides for the integrity of the enable signal given by the press control to the CES controller. Redundant CES inputs are provided to ensure that the enable signal is present and that the receiver is not shorted.

The enable signals consist of two press control contact closures that put the 115 VAC of the press control into the I/O board.

#### CLUTCH CONTACTOR ON (INPUT):

In addition to the enable, the press control provides 115 volts to energize the clutch contactor. This ensures that the press control has absolute control over the ability of the CES controller to energize the clutch. This input signal monitors the 115 volt signal. The clutch contactor ON signal is one of the signals that activate the CR1 relay.

#### INCH:

The inch signal indicates that the CES controller is directed to operate at inch

speed. The inch command is needed, along with enable, to activate the controller in the inch mode. The inch command can only be changed when the enable command is not present; otherwise, a fault will be generated.

The inch signal consists of a press control contact closure that puts the 115 VAC of the press control into the I/O board.

#### MICRO INCH:

The micro inch signal indicates that the CES controller is directed to operate at the micro inch speed. The micro inch command is needed, along with enable, to activate the controller in the micro inch mode. The micro inch command can only be changed when enable is not present; otherwise, a fault condition will be generated.

The micro inch signal consists of a press control contact

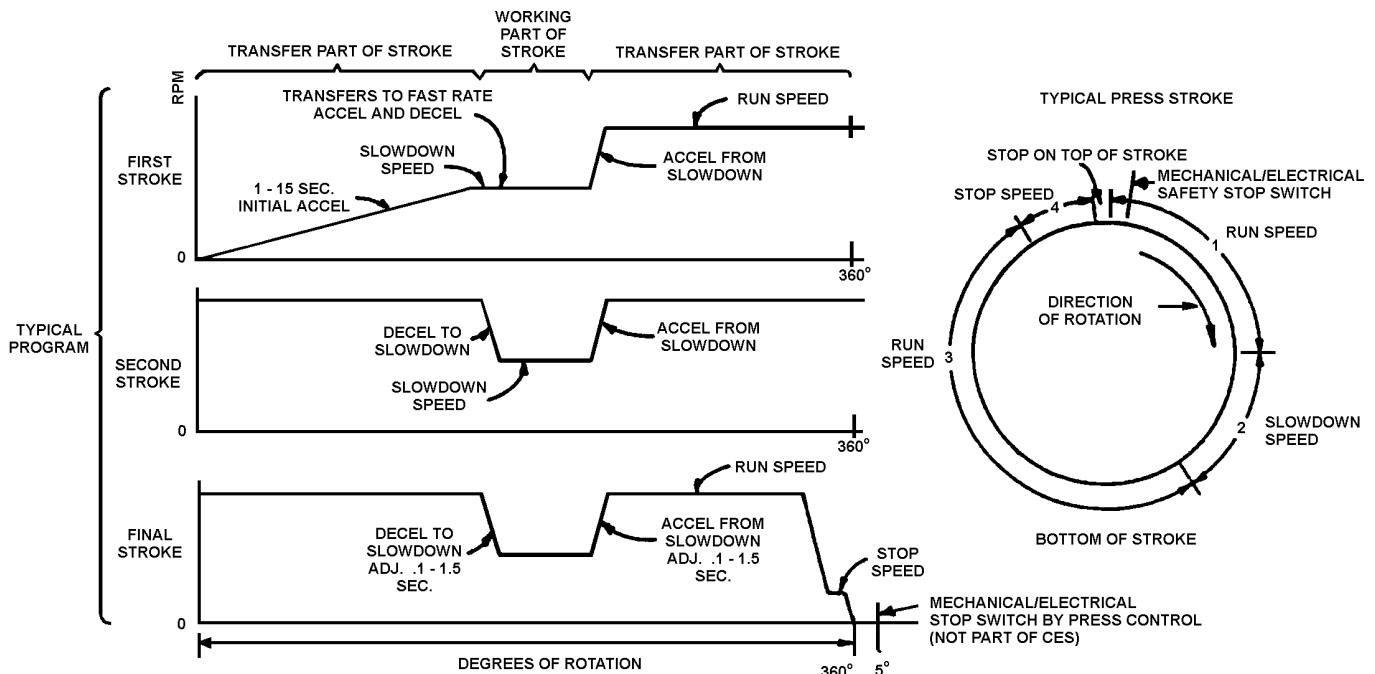

REFERENCE PROFILE AND ADJUSTABLE ANGLES FOR A CONTINUOUS OPERATING PRESS FIGURE 2-5

closure that puts the 115 VAC of the press control into the I/O board.

#### REVERSE:

The reverse command is sent to the press control to indicate that the press is to operate in the inch or micro inch mode in the reverse direction. The CES controller uses this information with other signals to establish either the inch-reverse or micro inch-reverse mode. If the reverse command is issued with any command other than the inch or micro inch, a fault will be generated. The reverse command cannot be changed when enable is present; otherwise, a fault will be generated.

The reverse signal consists of a press control contact closure that puts the 115 VAC of the press control into the I/O board.

#### CONTROL POWER ON:

The control power on signal is provided by the press control to activate the 115 VAC control power to the CES controller. This will close a contact in the secondary of the CES controller transformer.

#### STOP-ON-TOP:

The stop-on-top signal is issued by the press control to indicate that the CES controller should execute a normal stop-on-top, as described in detail in the section on "Press Operating Modes." If the stop-on-top command is present when the enable is received by the CES controller, a single stroke of the press will take place.

The stop-on-top signal consists of a press control contact opening that removes the 115 VAC of the press control to the I/O board.

#### FAULT RESET:

The fault reset command is a signal from the press control to reset any fault condition in the CES controller, allowing for continuation of operation. If the condition is a result of a clutch current fault or a brake current fault, it will be necessary to wait five to ten minutes (depending on the setting of parameters No. 64 for the clutch and No. 65 for the brake) before resetting; otherwise another fault will be generated. This delay is necessary to allow time for the coil to cool down. The time left to wait before restarting can be displayed in parameter No. 18. This time is in seconds.

The fault reset signal consists of a press control contact closure that puts the 115 VAC of the CES controller into the I/O board.

#### **PRESS CONTROL INTERFACE - OUTPUT SIGNALS**

The CES controller provides seven different solid state output signals that function as contact closures and contact openings, according to the conditions called for. The output signals that occur during different phases of operation are as follows: Normal Stop, Stop Main Motor

Fault, Stop Now Fault, Stop-on-Top Fault, Control Failure Fault, Clutch ON and TD Relay

#### NORMAL STOP (OUTPUT):

The normal stop signal from, the CES controller indicates that the press control is to execute a normal stop. Receipt of this signal from the CES controller indicates that the CES controller has commanded the press drive to be at zero speed. Upon receipt of this normal stop signal, the press control is directed to remove the enable signal and set the friction brake. The normal stop output will be cleared by the press control giving the enable signal the next time it is desired to run.

The I/O board of the CES controller opens a solid state relay contact for the normal stop signal to the press control.

#### STOP MAIN MOTOR FAULT (OUTPUT):

The stop main motor fault signal from the CES controller to the press control requests an emergency stop condition. The press control then stops the main motor, sets the flywheel brake, sets the friction brake and removes the enable signal. The CES controller is placed in the fault mode.

The I/O board of the CES controller opens a solid state relay contact for the stop motor fault signal to the press control.

#### STOP NOW FAULT (OUTPUT):

The stop now fault signal is an output from the CES controller. It indicates a second level of emergency stop in which the press control is to immediately remove the enable and set the friction brake. The software programs the reference to zero which applies the Eddy Current Brake to help stop the press.

The I/O board of the CES controller opens a solid state relay contact for the stop now fault signal to the press control.

#### STOP-ON-TOP FAULT:

The stop-on-top fault signal directs the press control to complete the present cycle, and then execute a normal stop-on-top, after which the CES controller is in the fault mode.

The I/O board of the CES controller opens a solid state relay contact for the stop-on-top fault signal to the press control.

#### CONTROL FAILURE FAULT (OUTPUT):

The control failure fault is generated by either of two conditions. One is when the microprocessor watchdog timer senses a microprocessor failure. The other is when the power supply monitors sense a failure.

The I/O board of the CES controller opens a solid state relay contact for the control failure fault signal to the press control.

#### CLUTCH ON (SIGNAL):

The clutch ON is a 115 volt output that drives the CR1 relay. A NO CR1 relay contact is in series with the 115 VAC power provided by the press control and a TD contact. Activating the CR1 relay and the TD relay will allow the clutch contactor to pull in after the press control has given the clutch ON command.

The CR1 contactor is activated by the following conditions:

1. Brake contactor is ON
2. Enable is present
3. No fault is present
4. Clutch contactor ON signal is present

Note: if the brake contactor drops out or clutch ON is removed, CR1 drops out immediately. If the enable is lost or either of the two emergency stop faults occurs, a 450 millisecond timer will be started, after which CR1 will be dropped out. CR1 is also dropped out 450 milliseconds after a normal stop.

#### TD RELAY:

A TD relay contact is in series with the CR1 contact closure to provide a redundant path for dropping out the ac contactor with the loss of the enable signal. The TD contact is closed when the enable input is present, and it drops out 600 milliseconds after the loss of enable.

#### PRESS CONTROL INTERFACE - SERIAL PORT

The serial interface assembly makes it possible for the DMR to communicate with another microprocessor or a main computer. This communication link is an RS-422 assembly that is mounted directly to the main DMR printed circuit board and is connected to the main board by a ribbon cable. It can be utilized to set references (i.e., speeds and angles) and to communicate diagnostic information, faults, etc.

#### SIGNALS FOR CUSTOMER'S RECORDER

The CES controller provides four different buffered signals at the terminals. They are as follows:

1. Clutch current
2. Brake current
3. Speed reference
4. Speed feedback

#### ANALOG METERS

The CES controller contains four analog meters to provide the service engineer with necessary operating parameters. They are as follows:

1. Clutch ammeter
2. Brake ammeter
3. Speed indication (SPM)
4. Elapsed time for clutch ON time

#### BRAKE CONTACTOR

A brake contactor is provided which will be closed under simultaneous conditions of control power ON being available and brake current fault not being present. The brake contactor is opened 10 seconds after stopping on top when a brake current fault is present.

#### PRESS OPERATING MODES

The CES controller includes 9 operating modes, as described in detail below. Among these are the four basic modes, employed in various combinations, as follows: Run, Fault, Test and Ready.

#### I .RUN MODE (NORMAL)

The CES controller is in the run mode if the following conditions exist:

1. Enable signal is present
2. NO fault is present
3. Reverse is not present
4. Inch is not present
5. Micro inch is not present
6. Clutch contactor ON is present
7. Brake contactor is closed

When in the run mode, the CES controller functions in the following manner.

A clutch ON command closes the clutch contactor. Upon initiation of the run mode, the drive reference signal ramps up from an initial value that is adjustable from 0 to 3 strokes per minute, at the initial acceleration rate, until the drive reference equals or exceeds the programmed reference. After this, the controller uses the operating acceleration/deceleration rates. The initial value of 0 to 3 strokes per minutes is adjustable at the keypad. It is parameter No. 48.

The operating accel and decel rates consist of three separately adjustable rates to minimize overshoot and undershoot of the slide speed. The first accel/decel rates are programmed to start by selecting the proper press angle. The second and third accel/decel rates are programmed based on a delta stroke per minute from the set point. The second rate is adjustable to start up to 25% of rated speed before the set point. The third rate is adjustable to start up to 15% of rated speed before the set point.

When in the run mode, the speed reference follows the profile set by the angles and speeds stored in the parameter locations as listed in Table 2-3 (also see Figure 2-5). Every angle and every speed must have an assigned value.

A setting of 360 degrees on any angle will cause the control to skip the speed setting that immediately follows.

**Parameter Locations Table 2-3**

Parameter Number	Data
30	Angle No. 1
31	Speed No. 1 (manual)*
32	Angle No. 2
33	Speed No. 2
34	Angle No. 3
35	Speed No. 3
36	Angle No. 4
37	Speed No. 4
38	Angle No. 5
39	Speed No. 5
40	Angle No. 6
41	Speed No. 6
42	Creep Angle ( $\alpha 7$ )
43	Stop Angle ( $\alpha 8$ )

NOTE: \*Parameter No. 31 will be the value of the Manual Speed pot, if one is used.

While in the run mode, when the press control receives a stop-on-top command, the CES controller will wait for the creep angle. Upon reaching the creep angle, the drive reference will decelerate to the creep speed and remain at creep speed until the stopping angle is reached. Upon reaching the stopping angle, the CES controller will set the reference at 0 and issue a normal stop signal to the press control. At the same time, the CES controller will initiate a 450 millisecond timer at the end, of which the clutch ON signal will be dropped, dropping out the clutch contactor. Upon receipt of the normal stop signal, the press control will enable the friction brake and remove the enable signal. The press control will remove the enable within 450 milliseconds; otherwise a stop now fault will be generated.

The 450 millisecond timer is included to ensure that clutch control excitation is removed regardless of other sequential operations in the event of some type of fault or failure.

Certain parameters can only be programmed from the keypad of the DMR. They are listed on Table 2-4.

The run mode will be indicated by the "Run" LED on the keypad and display board. Some controls have a full range manual Run Speed pot, others have a +/-5% manual Run Speed trim pot, while still others function without any speed pot. Both pots are effective when the press starts up and after the press passes Angles No. 1.

## II. INCH FORWARD MODE (RUN AT)

The CES controller will be in the inch forward mode if the following conditions exist:

1. Enable signal is present

2. No fault is present
3. Reverse is not present
4. Inch is present
5. Micro inch is not present
6. Clutch contactor ON signal is present
7. Brake contactor is closed

**Keypad Programming Table 2-4**

Parameter Number	Data
44	Creep Speed
45	Micro Inch Speed
46	Inch Speed
47	Inch Accel Rate
48	Initial Value of Linear Accel Ramp
49	Initial Accel Rate (A1)
50	Operating Accel Rate No. 1
51	Operating Accel Rate No. 2
52	Operating Accel Rate No. 3
53	Accel Rate Delta SPM No. 1
54	Accel Rate Delta SPM No. 2
55	Operating Decel Rate No. 1
56	Operating Decel Rate No. 2
57	Operating Decel Rate No. 3
58	Decel Rate Delta SPM No. 1
59	Decel Rate Delta SPM No. 2
73	Baud Rate
75	Die Contact Angle
78	Gear Ratio
79	Pulses per Revolution
80	Pot Selector
81-Optional	Stop-on-Bottom – Creep Speed Angle
82-Optional	Stop-on-Bottom – Apply Brake Angle
83-Optional	Creep Speed Bottom

When in the inch forward mode, the CES controller functions in the following manner.

The clutch ON command closes the clutch contactor. The reference ramps from 0 to the inch reference at the inch acceleration rate. Upon removal of the enable, the drive reference goes immediately to 0 and the drive decelerates to zero speed. At the time the enable is removed, the 450 millisecond clutch safety timer is initiated. After 450 Milliseconds the clutch contactor is dropped out by removing clutch ON. The enable signal should be the last signal received to eliminate faults. The drive may be jogged in the inch mode by toggling the enable signal.

The inch forward mode will be indicated by the "Inch" LED on the keypad and display board.

### III. INCH REVERSE MODE (RUN AT)

The CES controller will be in the inch reverse mode if the following conditions exist:

1. Enable signal is present
2. No fault is present
3. Reverse is present
4. Inch is present
5. Micro inch is not present
6. Clutch contactor ON signal is present
7. Brake contactor is closed
8. The main motor is programmed to run in the reverse direction

When in the inch reverse mode, the CES controller functions in the following manner.

The clutch ON command closes the clutch contactor. The reference ramps from 0 to the inch reference at the inch acceleration rate. Upon removal of the enable, the drive reference goes immediately to 0 and the drive decelerates to Zero speed. At the time the enable is removed, the 450 millisecond clutch safety timer is initiated. After 450 milliseconds, the clutch contactor is dropped out by removing clutch ON. The enable signal should be the last signal received to eliminate faults. The drive may be jogged in the inch mode by toggling the enable signal.

The inch reverse mode will be indicated by simultaneous illumination of the "Inch" and "Reverse" LEDs on the keypad and display board.

### IV. MICRO INCH FORWARD MODE (RUN AT)

The CES controller will be in the micro inch forward mode if the following conditions exist:

1. Enable signal is present
2. No fault is present
3. Reverse is not present
4. Inch is not present
5. Micro inch is present
6. Clutch contactor ON signal is present
7. Brake contactor is closed

When in the micro inch forward mode, the CES controller functions in the following manner,

The clutch ON command closes the clutch contactor. The reference ramps from 0 to the micro inch reference. There is no acceleration rate in micro inch. Upon removal of the enable, the drive reference goes immediately to 0 and the drive decelerates to zero speed. At the time the enable is removed, the 450 millisecond clutch safety timer is initiated. After 450 milliseconds, the clutch contactor is dropped out by removing clutch ON. The enable signal should be the last signal received to eliminate faults. The drive should be jogged in the micro inch mode by toggling the enable signal.

The micro inch forward mode will be indicated by the "Micro Inch" LED on the keypad and display board.

### V. MICRO INCH REVERSE MODE (RUN AT)

The CES controller will be in the micro inch reverse mode if the following conditions exist:

1. Enable signal is present
2. No fault is present
3. Reverse is present
4. Inch is not present
5. Micro inch is present
6. Clutch contactor ON signal is present
7. Brake contactor is closed
8. The main motor is programmed to run in the reverse direction

When in the micro inch reverse mode, the CES controller functions in the following manner.

The clutch ON command closes the clutch contactor. The reference ramps from 0 to the micro inch reference. Upon removal of the enable, the drive reference goes immediately to 0 and the drive decelerates to zero speed. At the time the enable is removed, the 450 millisecond clutch safety timer is initiated. After 450 milliseconds, the clutch contactor is dropped out by removing clutch ON. The enable signal should be the last signal received to eliminate faults. The drive may be jogged in the micro inch mode by toggling the enable signal.

The micro inch reverse mode will be indicated by simultaneous illumination of the "Micro Inch" and "Reverse" LEDs on the keypad and display board.

### VI. FAULT MODE

Two fault indicators designed into the controller are the DMR Fault and First Fault (15-775-2).

The fault mode is entered if any fault is generated. Once the fault mode has been entered by the initiation of a fault, the CES controller remains in the fault mode until the fault mode is remotely reset by the press control issuing a fault reset command. The fault mode can be reset locally from the CES controller keypad. Call up Parameter 63, Clear Faults, and using the Down Arrow (↓) reduce the faults to zero.

In the fault mode, various faults are stored, indicated and transmitted to the press control by the CES controller. In the case of all faults, the press is stopped. There are various levels of faults; and the urgency with which the press is stopped differs with the different levels of faults. The four faults that the CES controller will diagnose are as follows: Stop Main Motor Fault, Stop Now Fault, Stop-On-Top-Fault and Control Fault. These are fully described below. For quick reference during operation, refer to Table 3-3 and/or 3-4.

When a level 0100, 0200 or 0300 fault exists it will be indicated by an LED on the keypad and display board. A control fault will be indicated by the absence of the "control fault" LED on the I/O PCB.

Stop Main Motor Fault - There is only one fault that will signal the stopping of the main motor in addition to stopping the press. It is Fault No. 0101, Over-speed Fault.

0101 Over-speed Fault - An over-speed condition is defined as follows: If the tach feedback signal exceeds the speed reference by a set percentage, an over-speed condition exists. The time allowed to be over-speed, before a fault is recognized, is adjustable from 0 to 5 seconds. The over-speed percentage is adjustable from 0 to 20%. The reason the main motor is stopped in this case is that it is considered to be in a runaway condition. Set for minimum time and minimum over-speed percent without causing nuisance tripping of fault.

When the over-speed fault is generated, the CES controller functions in the following manner.

Upon sensing the over-speed fault, a stop motor fault signal is sent to the press control to remove enable and initiate the stopping sequence; this includes setting the friction brake and removing enable from the CES controller. Speed reference is set to zero. The clutch converter is inhibited. The clutch contactor drop out timer is initiated immediately upon detection of an over-speed fault. The timer will cause the clutch contactor to drop out in 450 milliseconds by removing the clutch ON command to the contactor. The brake will be energized by the negative speed error, while the speed is above zero, to provide decelerating torque.

Stop Now Faults - There are 18 stop now faults. They require the press to be stopped immediately, but not the main motor. Each of these faults is described as follows:

- 0202 Loss of Tach Fault - Loss of encoder pulses with 10% of clutch current for 200 milliseconds.
- 0203 Clutch Current Delay Fault - If 10% current is present in the clutch coil when CR1 is de-energized, a clutch current delay fault will be issued.
- 0206 Press Movement in Wrong Direction Fault - Press movement detected to be in a direction opposite of that commanded, based upon degrees of opposite rotation after enabled. The number of degrees of rotation before causing this fault is adjustable from 0 to 10 degrees at the keypad. Set for minimum degrees without causing nuisance tripping.

- 0207 Loss of Line Fault - Loss of an input phase or greater than 20% drop in ac line for a period of 100 milliseconds.
- 0208 Enable Without Clutch Contactor ON Fault - Clutch contactor ON is not present within 170 milliseconds of receiving enable (see Fault No. 0226).
- 0209 Clutch Contactor ON After Clutch ON is De-energized Fault - Clutch contactor ON input signal is present 100 milliseconds after clutch ON output is de-energized.
- 0210 Missing Enable Fault - The two enable signals are not coincident for more than 170 milliseconds.
- 0211 Inch + Micro Inch + Enable Fault - The presence of an inch and micro inch command with enable.
- 0212 Reverse Command Fault - The presence of a reverse command without an inch or a micro inch command.
- 0220 Enable Present After Normal Stop Fault - Enable present 450 milliseconds after a normal stop is issued.
- 0221 Clutch Contactor Not ON In Test Mode Fault - Clutch contactor ON signal, not present while in clutch test mode.
- 0222 Press Movement in Test Mode Fault - Press movement of 2 degrees detected while in test mode.
- 0223 Enable Present In Test Mode Fault - Enable signal present while in test mode.
- 0224 Stop-On-Top Not Performed Fault - The stop-on-top function failed to stop the press in 1.5 times the cycle period.
- 0225 Clutch Contactor ON Removed without removing enable fault or clutch contactor removed during the 450 milliseconds required before de-energizing the clutch contactor.
- 0226 Clutch Contactor ON Without Enable Fault - Enable not present within 170 milliseconds of receiving clutch contactor ON (see Fault No. 0208).
- 0227 Enable Before Cool Down Expired Fault - Enabling the CES controller before the cool down time period has expired following a clutch current or a brake current fault.



0228 Creep Speed Not Reached Before Stop Angle Fault - During a stop-on-top sequence, the creep speed is not reached before the press reaches the stop angle.

When any stop now fault is generated, the CES controller functions in the following manner.

A stop now fault will be issued to the press control immediately upon sensing any of the above faults. The press control should initiate an emergency stopping sequence that includes setting the holding brake and removing the enable from the CES controller (among other items). Speed reference will be set to zero. The clutch converter is inhibited. The clutch contactor drop out timer is initiated immediately upon detection of a stop now fault. The timer will cause the clutch contactor to drop out in 450 milliseconds by removing the clutch ON command to the contactor. The brake will be energized by the negative speed error, while the speed is above zero, to provide decelerating torque.

Stop-On-Top Faults - There are 8 stop-on-top faults. They will cause the CES controller to execute a normal stop upon reaching the top of the press stroke. These faults do not require an emergency stop, but should stop the press at the top during the next cycle in order for the problem to be investigated. Each of these faults is described as follows:

0313 Under-speed Fault - If the tach signal is 3% less than the speed reference, an under-speed fault will exist. The time allowed to be under speed is adjustable from 0 to 5 seconds. Reset at speed error within 3%.

0314 Clutch and Brake Current Overlap - If clutch and brake current are present at the same time, a clutch and brake current overlap fault will exist. The overlap time allowed is 0.5 second and the amount of overlap allowable is 5%.

0315 Clutch Current Fault - If clutch current is present for too long, a clutch current fault will exist. The time allowed is adjustable from 3 to 20 seconds and the current allowable is 20%. The CES controller cannot be enabled until cool down time has expired.

0316 Brake Current Fault - If brake current is present for too long, a brake current fault will exist. The time allowed is adjustable from 3 to 20 seconds and the current allowable is 20%. The CES controller cannot be enabled until cool down time has expired.

0317 Inch Change Fault - If the inch command signal is changed while enable is present, an inch change fault will exist.

0318 Micro Inch Change Fault - If the micro inch command is changed while enable is present, a micro inch change fault will exist.

0319 Reverse Change Fault - If the reverse command is changed while enable is present, a reverse change fault will exist.

0329 Parameter Out of Limits Fault - If a downloaded parameter is outside of established limits a parameter out of limits fault will exist. When commanded to use the new parameters that contain a parameter that is outside of the established limits, the controller will operate at the established limit of the incorrect parameter and create a stop-on-top fault.

When any stop-on-top fault is generated, the CES controller functions in the following manner:

A stop-on-top fault output is issued to the press control. A normal stop sequence will be initiated (normal stop-on-top operation). At the completion of this sequence, the drive will be in a fault mode condition and cannot be restarted without resetting the fault. If the press does not reach the stopping angle in 1.5 times the press cycle period, the CES controller will issue a stop now fault.

Control Faults - A microprocessor watchdog timer monitors the microprocessor and the power supply for proper operation. The CES controller issues a control failure fault any time either one fails or goes out of tolerance. This type of fault will produce a Stop Now stop.

#### **FAULT PRIORITY ENCODER**

Various conditions have been selected to be monitored as faults. The faults, in order of priority, are as follows:

- Run Signal is Present
- 0 Push Reset
- 1 External
- 2 Brake Free Wheel
- 3 Low Line
- 4 Brake Over-current
- 5 Clutch Free Wheel
- 6 Line/Microprocessor
- 7 Clutch Over-current

In order to read these faults accurately, a PWM Fault Indicator board, No. 15-775-2, must be plugged into the corresponding header on the DMR. For a quick reference during operation, refer to Table 3-3.

#### **VII. SET-UP/TEST MODE**

The test mode can only be accessed when the main motor is OFF and press power is padlocked OFF. In order to enter, use, and exit the test mode, the following steps must be followed in the order given:

1. CES controller power is applied
2. Enable is not present
3. No fault is present
4. Test mode parameter No. 60 is set to the ON condition from the keypad and display board
5. CES circuit breaker opened to remove power
6. Main motor and press control power is OFF
7. Jumper across CR2 contacts 15 and 16 on TB14
8. Jumper across TD contacts 26 and 27 on TB14
9. Jumper control power across contacts 300 and 302
10. Incoming leads 320, 321 and 334 removed from TB10. Tape ends
11. Jumper 115 volts from 302 to 320 and 301 to 334 on TB10
12. CES circuit breaker closed to reapply power
13. Clutch test and/or brake test performed as required
14. CES circuit breaker opened to remove power
15. Remove jumpers and replace leads that were changed in steps 7, 8, 9, 10 and 11 above
16. CES circuit breaker closed to reapply power
17. Exit test mode by setting parameter No. 60 to the OFF condition from the keypad and display board

An LED located on the keypad and display board indicates the test mode. The test mode is only de-energized by setting parameter No. 60 to OFF. The test mode is stored in non-volatile memory.

Clutch Test Mode - In the test mode, the clutch test mode can be entered by setting the clutch test mode parameter to ON (parameter No. 61, up arrow (↑)).

The clutch will be engaged full ON with the DMR automatically doing the following:

1. Issuing a clutch ON command
2. Setting reference to 100%
3. Setting feedback to 0%
4. Releasing the DMR inhibit

In the clutch test mode, the clutch is de-energized by doing the following:

1. Setting parameter No. 61 to OFF (down arrow (↓))
2. Exiting the test mode or
3. Entering the brake test mode

De-energizing the clutch test mode initiates the following sequence:

1. Reference and feedback are set to 0%
2. DMR inhibit is activated
3. The clutch ON command is dropped after 450 milliseconds

Brake Test Mode - In the test mode, the brake test mode can be entered by setting the brake test mode parameter to ON (parameter No. 62, up arrow (↑)).

The brake will be engaged full ON with the DMR automatically doing the following:

1. Issuing a brake ON command
2. Setting reference to 0%
3. Setting feedback to 100%

In the brake test mode, the brake is de-energized by doing the following:

1. Setting parameter No. 62 to OFF (down arrow (↓)).
2. Exiting the test mode or
3. Entering the clutch test mode

De-energizing the brake test mode initiates the following:

1. Reference and feedback are set to 0%

Test Mode Faults - Receiving an enable in the test mode will result in an enable in the test mode fault. Sensing press movement in the test mode will initiate a press movement in the test mode fault.

### VIII. READY MODE

The CES controller will be in the ready mode if the following conditions exist:

1. CES control power is applied
2. It is not in the run, test or fault modes

The ready mode will be indicated by the "Ready" LED on the keypad and display board.

### IX. SPEED CONTROL REFERENCE CLAMP

The CES controller has a maximum speed setting. If the press control sends a speed reference value that is greater than this maximum speed to the CES controller, the CES controller will clamp the reference at the maximum speed. The "Referenced Clamped" LED will light on the keypad and display board, indicating that the reference is clamped.

### PRESS CONTROL PARAMETERS

The press control may have constraints on changing of speeds and press drive parameters while the press is running. The CES controller will change parameters as directed by the press control.

Press control parameters are sent by the press control in a packet of bits representing ASCII characters. The first two ASCII characters will be AA. The packet length is 68 characters. Space characters are used to complete the 68-character packet. Upon receiving an EE command, the AA packet will be transmitted back to the press control by the DMR for comparison to ensure its accuracy. The AA will be changed to EE when sent back.

Fault data is sent by the CES controller upon request of the press control. The two ASCII characters of the "Request to Send Fault Data" will be BB. The packet length of the request will be two characters. The DMR will send the fault data in a packet of bits representing ASCII characters. The first two ASCII characters will be BB. The remaining characters will be four digit numbers,

which will represent faults corresponding to these numbers. Zeros are used to complete the 68-character packet.

Monitor data will be sent by the DMR on request of the press control. The two ASCII characters of the "Request to Send Monitor Data" will be CC. The packet length of the request will be two characters. The DMR will then send the monitor data in a packet of bits representing ASCII characters. The first two ASCII characters will be CC. The remaining characters will contain the monitor data. Zeros are used to complete the 68-character packet. Numbers in the monitor data will be four digits with an implied decimal point.

When ready, the press control will send a two-character packet to the CES controller instructing the DMR to execute the new parameters. The two ASCII, characters in this packet of bits will be DD. All characters in the packet will be 8 bit ASCII (the most significant bit being zero) with one start, one stop and no parity.

In the run mode the new parameters will take effect at the first angle after the press reaches the top of the stroke after having received the DD command to execute the new parameters. If the press is stopped, or is operating in the inch or micro inch mode then the DD command to execute the new parameters is given, the new parameters will take effect immediately. There are no termination characters for the packets.

The press run data packet should contain the following information, and in the order given:

1. ASCII characters AA.
2. Six independent angles and speeds defined in pairs. The angles are in degrees and are defined in a clockwise (CW) rotation with zero degrees at top dead center. The speeds are in strokes per minute. If it is desired to skip an angle, it may be programmed to be 360.0 degrees and, since the press will only accept angles from 0 to 359.9 degrees, it will skip the angle programmed for 360.0 degrees.
3. The seventh angle will be the angle that starts slowing the press down to the creep speed after the CES controller has received the stop-on-top contact closure.
4. The eighth angle will be the angle to initiate the contact that will allow the press control to set the friction brake after the press has been at creep speed and reaches this stop angle.
5. The angles will be four digits with an implied decimal point, in tenths of a degree ranging from 0 to 359.9 degrees.
6. The speeds will be four digits, with an implied decimal point, in hundredths of a stroke per minute.

7. The press run data should have the format indicated in Table 2-5.

**Press Run Data Format Table 2-5**

Packet Number	Data	Par No.
1 through 2	AA	
3 through 6	Angle No. 1	30
7 through 10	Speed No. 1	31
11 through 14	Angle No. 2	32
15 through 18	Speed No. 2	33
19 through 22	Angle No. 3	34
23 through 26	Speed No. 3	35
27 through 30	Angle No. 4	36
31 through 34	Speed No. 4	37
35 through 38	Angle No. 5	38
39 through 42	Speed No. 5	39
43 through 46	Angle No. 6	40
47 through 50	Speed No. 6	41
51 through 54	Creep Angle	42
55 through 58	Stop Angle	43
59 through 68	Zeros	

**CES Monitor Data Format Table 2-6**

Packet Number	Data
1 through 2	CC
3 through 6	Inch Speed
7 through 10	Micro Inch Speed
11 through 14	Creep Speed
15 through 18	Operating acceleration rate No. 1
19 through 22	Operating acceleration rate No. 2
23 through 26	Operating acceleration rate No. 3
27 through 30	Acceleration rate delta SPM No. 1
31 through 34	Acceleration rate delta SPM No. 2
35 through 38	Operating deceleration rate No. 1
39 through 42	Operating deceleration rate No. 2
43 through 46	Operating deceleration rate No. 3
47 through 50	Deceleration rate delta SPM No. 1
51 through 54	Deceleration rate delta SPM No. 2
55 through 58	Initial acceleration rate
59 through 62	Average parts per minute
63 through 66	Speed Reference
67 through 68	Zeros

The CES monitor data packet will contain the following information:

1. ASCII characters CC.
2. Acceleration and deceleration rates will be four digits, with an implied decimal point, in tenths of a stroke.
3. The speeds will be four digits, with an implied decimal point, in hundredths of a stroke per minute.
4. The CES monitor data will have the format indicated in Table 2-6 per minute per second.

A typical program to run a press with a Manual Speed pot and use the slowdown function to get good parts would be set up as follows:

1. Angle No. 1 = 180 degrees
2. Manual Speed pot = 16 SPM
3. Angle No. 2 = 115 degrees
4. Speed No. 2 = 10 SPM
5. Angle No. 3 = 360 degrees
6. Speed No. 3 = 10
7. Angle No. 4 = 360 degrees
8. Speed No. 4 = 10
9. Angle No. 5 = 360 degrees
10. Speed No. 5 = 10
11. Angle No. 6 = 360 degrees
12. Speed No. 6 = 10
13. Creep Angle = 305 degrees
14. Stop Angle = 356.5 degrees
15. On the keypad, enter:  
    Creep Speed = 3 SPM

## OPERATION

### PURPOSE

The CES Stamping Press Controller is easy to operate. We believe that some knowledge of how the controller is supposed to function will help you obtain the best performance with minimum down time. Knowing how it works will also help you troubleshoot any problems that may arise. Before applying power to the controller, we suggest that you read this section.

### CONSTANT ENERGY SYSTEM

The Constant Energy System (CES) is an advancement in metal forming press drive systems employing an eddy-current clutch and brake in place of friction devices and utilizing the eddy-current clutch as an adjustable stroking rate drive. The name, Constant Energy System, is derived from the physical arrangement of the components of the system; the flywheel of the eddy-current drive is coupled to a constant speed motor. Therefore, constant kinetic energy is maintained in the flywheel. The CES press drive has proved itself capable of speed controlling large stamping and draw presses over wide speed ranges. It is also readily adaptable to synchronizing or position controlling several presses.

The CES control system is infinitely variable throughout its speed range of 10:1. It is capable of precise position control; such as in very slow inching for die setup. Input flywheel size and motor horsepower affect system performance at low output speeds and maximum loads. Thus, proper sizing of the press drive for the specific operating speed range of your press application is an important factor.

### STAMPING PRESS OPERATION

Stamping presses generally employ either 5 to 8% or 8 to 13% high slip ac motors belted to a flywheel, a friction clutch and brake, and press gearing that drives the press crank shaft. DC motors have also been used for this purpose. One critical part of a modern mechanical press is the overworked clutch and brake units. The function of the clutch is to deliver torque from the flywheel to the crankshaft for the working of metal. If the press is single stroked, the clutch must accelerate the gears and other rotating members from zero to full operating speed, and also transmit the required working torque. The brake must decelerate the rotating parts in order to stop the slide. The many types of clutch and brake units built by various press builders and their suppliers can all be classified in one of the following categories: 1) Positive clutch and brake; 2) Friction clutch and brake; and 3) Eddy-current clutch and brake.

### EDDY-CURRENT CLUTCH AND BRAKE

The eddy-current clutch and brake unit is basically a press drive utilizing the eddy-current principle to transmit and control the required crank torque. The drive consists of a flywheel, belt driven by a high slip ac induction motor, an eddy-current clutch rotor and a brake rotor assembly directly connected to the press drive shaft.

Driving torque is developed through an electromagnetic force between the flywheel and clutch rotor. Braking torque is developed through a similar force between the stationary brake field assembly and the brake rotor. Electromagnetic coils in the flywheel or brake field assembly are energized to establish a magnetic field that cuts through the surface of the clutch and brake rotors. Relative motion between the clutch rotor and the clutch field poles, or between the brake rotor and brake field poles, causes a cutting action of the magnetic flux at the rotor surface, which in turn generates eddy-currents in the drum. Torque transmitting magnetic action is then induced between the clutch rotor and flywheel member, or between the brake rotor and brake field member. The degree of clutching or braking action is controlled by varying the magnitude of the current fed to the coils.

Since the eddy-current brake does not develop any torque at zero rpm, a friction brake is used as a holding brake. This brake must be large enough to be capable of stopping the press in an emergency, such as a power failure.

### VARIABLE SPEED PRESS DRIVES

The package press drive consists of an integral flywheel, air-cooled, eddy-current clutch and brake in a standardized, interchangeable package design. With the advent of high power capability electronic components, it became possible to build a high performance speed control capable of maintaining set speed of the package press drive anywhere within the mechanical press drive's speed range. Since the flywheel is directly belted to the main drive motor and run at a constant speed, it has a fixed level of energy available for transmission to the work through the eddy-current clutch.

The press drive can be geared to the highest press running speed. Since the primary mass is the flywheel, and the output member has relatively low inertia, the press drive is capable of varying its running speed during different portions of a single stroke. The press can approach the work at high speed, slow down just prior to hitting the work, go at optimum metal working speed and complete the stroke at high speed. The end result is more parts per hour.

The heart of the CES stamping press controller is the CES Controller. Its purpose is to provide high response velocity control. It is adaptable also to position the slide where line synchronization is desirable. The basic CES controller is a high field forcing speed device using closed loop control.

In a closed loop controller, a portion of the output signal is fed to the feedback network and then to a summing junction in opposition to a reference signal. If there is a difference between the feedback and reference signals, the resultant error signal is used for controlling the output speed. One closed loop system is used for

velocity control and another one for current limit. A simple closed loop system is shown in Figure 3-1.

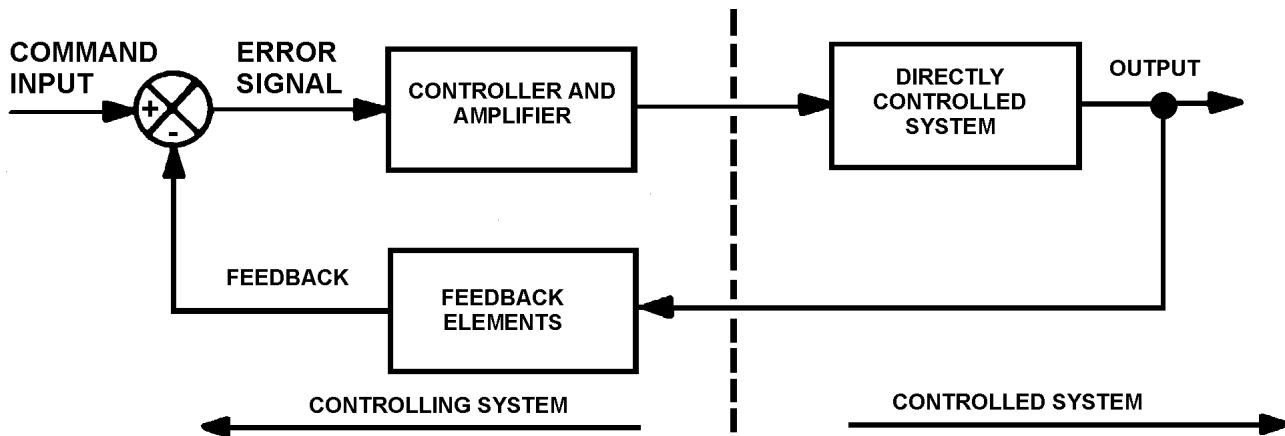

**SIMPLE CLOSED LOOP SYSTEM**

**FIGURE 3-1**

**POWER AMPLIFIER**

The power amplifier is a high current capacity SCR power section capable of supplying four times rated voltage (field forcing) to the clutch and brake coils. Field forcing reduces the effective coil time constant. One time constant is defined as the time required for the current in a coil to reach 63% of its final value with a step change in voltage. With a step change in voltage, the current rises exponentially. Over-volting, or field forcing, is a method for reducing the effective time constant. A current feedback loop is used with the CES controller to limit the current to its rated value by cutting back on the voltage as 100% current is approached.

For proper operation of the press drive, a separation must be maintained between the brake and clutch. If the proper separation is not maintained, an overlap condition can result which pre-loads the motor. Separation between clutch and brake action is necessary to ensure against simultaneous braking and clutching.

When the speed reference is increased, a positive voltage is applied at the positive input of the clutch error amplifier to turn the clutch power amplifier on. This same voltage is applied to the negative input of the brake error amplifier to turn the brake power amplifier off. The clutch remains on until the voltage output from the tachometer feedback equals the speed reference voltage. At that time, the error amplifier instantly turns to a zero volt output to the power amplifier thereby discontinuing power to the clutch.

If the speed reference voltage is reduced, the opposite effect takes place. The tachometer feedback voltage then exceeds the reference and the clutch error amplifier drives the clutch power amplifier off. This puts a positive input on the brake error amplifier, driving the brake power amplifier on. By braking to slower speeds, the

tachometer feedback voltage is reduced in direct proportion to the reduction of the press speed until the speed reference voltage equals the tachometer feedback voltage. The brake then turns off. Thus, changes in speed setting can be reacted to quickly with either the clutch or brake being energized as required.

The current limit loop function is similar to the speed control loop, except that current is sensed by an LEM in series with the clutch and brake coils. This network acts as a current limit to hold control current output to a safe level while providing maximum voltage forcing for response.

**CES LOGIC BOARD**

The primary function of the logic board is to issue properly timed output gate signals to the brake and clutch gate driver circuit boards that are based upon the following four inputs: reference signal input from the digital main regulator (DMR); coil current feedback from the LEM sensors; amplitude and phasing of the ac lines; and speed feedback from the DMR. The abbreviations, "DFE" and "CDB" which were used previously for Digital Front End and Computer Digital Board respectively, may be interchanged with "DMR" in this manual and elsewhere.

In addition, other logic conditions determine whether clutch phase up is permitted, such as run signal and DMR inhibit. Coil voltage is sensed and used in separate circuits to generate free wheel gate commands.

The reference and feedback voltages are processed separately for the clutch and brake, including separate microprocessor full converter phase shifters. This provides a clear separation of signals and functions.

The link with the DMR is a 26-line ribbon cable. This cable also connects to the interface indicator board; however, this board is not required in order to run. A separate 8-pin cable, PL-Fault, connects to the DMR and converts various logic state conditions. Six other connections that are used are as follows:

PL-LEM - A 6-pin connection to the current sensors.

PL-PS - A 7-pin cable. Five of the wires bring the power supply voltages to the logic board with two of the wires looped through to the DMR.

PL-FP - Connections to the front panel terminals.

PL-MTR - Connections to the meters and CR2 relay.

PL-CLUTCH A 16-pin dip ribbon connector to the clutch gate driver board.

PL-BRAKE - A 16-pin dip connection to the brake gate driver.

There are only six adjustments to the logic board, and they are as follows: Clutch Current Limit, Clutch Current Damping, Clutch Velocity Damping, Brake Current Limit, Brake Current Damping and Brake Velocity Damping.

The clutch and brake are operated similarly, but separately, with each having its own error and control amplifiers. Therefore, in the following discussions where reference is made only to the clutch, it will be equally applicable to the brake; when there are differences, specific references are made to the brake.

### LOGIC POWER SUPPLY INPUTS

Power supply voltages connected at PL-PS are as follows: +5 V, +12 V, -12 V, +24 V, power COM (common) and signal COM. C20 through C27 provide noise filtering. ZD1 is a precision voltage reference zener diode that provides a stable +2.5 V for the on-board comparators. Test points J10 through J15 are available for checking the supply voltages: J10 = +5 V; J11 = +2.5 V; J12 = +12 V; J13 = COM; J14 +24 V; J15 = -12 V. The +12 V and COM are routed to the interface indicator board through the 26-pin logic to DMR-23 and DMR-26. Dual inputs for + 12 V, -12 V and signal COM are for continuation of wiring to the DMR.

### LOGIC CONTROL LINES

Coordination between clutch and brake is accomplished by the comparator U1-C, which compares the reference input from the DMR and speed feedback. It prevents the clutch and brake from being energized simultaneously, in order to prevent overlap, by producing a high on the control line. Any high on the control line inhibits further operation.

A high on the control line can also be caused by other factors. For the clutch, it can be caused by the absence of a run signal input; clutch contactor not pulled in; DMR inhibit signal present; 120% rated clutch coil current; or

85% rated line voltage or missing phase. For the brake, it can be caused by the brake contactor not being pulled in; 120% rated brake coil current; or 85% rated line voltage or missing phase.

### LEM CURRENT FEEDBACK AMPLIFIERS

Both clutch and brake Hall effect current feedback transducers are connected to the logic board at PL-LEM (on the Logic PCB). The values of R5 and the number of LEM turns are selected at the factory to produce an output of approximately 7 V at rated current. The same is true for the value of R131 (also on the Logic PCB) and its related number of LEM turns. This is necessary to avoid having to change over-current trip points and other current dependent scalars for different size press drives. See Table 3-1 for values normally specified for each size press drive.

**LEM Current Feedback Values Table 3-1**

Mechanical Unit	I (CL) I (BK)	LEM nT	R5 R131
49-63	180 A	1	28.7K
	90 A	2	28.7K
49-42	120 A	1	60.4K
	60 A	2	60.4K
37-42	96 A	1	84.5K
	48 A	2	84.5K
37-32	72 A	2	124.0K
	48 A	2	84.5K
37-21	48 A	2	84.5K
	24 A	4	84.5K

### FAULT PRIORITY ENCODER

Various conditions have been selected to be monitored as faults. The faults, in order of priority, are listed in Table 3-3 under "Fault Indicator."

In order to read these faults accurately, a PWM Fault Indicator board, No. 15-775-2, must be plugged into the corresponding header on the DMR.

### FAULT CODES

A list of all fault numbers is included in Table 3-3 and 3-4 to serve as a quick reference during operation. For a more complete explanation of these numbers, refer to Section 2. The only stop main motor fault number is 0101. Stop now fault numbers range from 0202 through 0228. Stop-on-top fault numbers range from 0313 through 0329.

### CES CONTROLLER PARAMETERS

Parameter values are set either from the keypad or through the serial interface. The last value set from either method is maintained in nonvolatile memory. Keypad parameters are set by entering the parameter number through the keypad and incrementing the value

to the desired number with the up arrow (↑) or down arrow (↓).

A list of all parameter numbers is included in Table 3-3 and 3-4 to serve as a quick reference during operation. Parameters that can only be displayed are numbered 01

through 25. The remaining parameters can be modified from the keypad. Parameters that can be downloaded through a serial interface are numbered 30 through 43. Some parameters have built in limits. Refer to Table 3-2 for the parameter numbers have limits set.

**Parameter Limits**

**Table 3-2**

Parameter Number	Parameter Description	Limits	Units
26	Maximum Speed	Speed of press	SPM
30*	Angle No. 1	0 - 359.9	Degrees
31*	Speed No. 1	Speed of press	SPM
32*	Angle No. 2	0 - 359.9	Degrees
33*	Speed No. 2	Speed of press	SPM
34*	Angle No. 3	0 - 359.9	Degrees
35*	Speed No. 3	Speed of press	SPM
36*	Angle No. 4	0 - 359.9	Degrees
37*	Speed No. 4	Speed of press	SPM
38*	Angle No. 5	0 - 359.9	Degrees
39*	Speed No. 5	Speed of press	SPM
40*	Angle No. 6	0 - 359.9	Degrees
41*	Speed No. 6	Speed of press	SPM
42*	Creep Angle		Degrees
43*	Stop Angle	5	Degrees
44	Creep Speed	5	SPM
45	Micro Inch Speed	25% of max.	SPM
46	Inch Speed	50% of max.	SPM
47	Inch Accel Rate	1 - 100	SPM/Sec.
48	Initial Value of Linear Accel Ramp	0 - 3	SPM
49	Initial Accel Rate	1 - 100	SPM/Sec.
50	Operating Accel Rate No. 1	1 - 100	SPM/Sec.
51	Operating Accel Rate No. 2	1 - 100	SPM/Sec.
52	Operating Accel Rate No. 3	1 - 100	SPM/Sec.
53	Accel Rate Delta SPM No. 1	1 - 5	SPM
54	Accel Rate Delta SPM No. 2	1 - 5	SPM
55	Operating Decel Rate No. 1	1 - 100	SPM/Sec.
56	Operating Decel Rate No. 2	1 - 100	SPM/Sec.
57	Operating Decel Rate No. 3	1 - 100	SPM/Sec.
58	Decel Rate Delta SPM No. 1	1 - 5	SPM
59	Decel Rate Delta SPM No. 2	1 - 5	SPM
70	Wrong Direction Limit	0 - 10	Degrees

NOTE: \*These parameters can be downloaded through a serial interface.



## KEYPAD PROGRAMMING

The keypad is mounted integrally with the DMR. It is connected to the main DMR through a ribbon cable and is used for viewing and modifying various parameters within the systems. The module consists of the following: a 20-button keypad; two independent sets of 8-digit, 7-segment LED displays; and a row of 8 individual status LEDs. The keypad is illustrated in Figure 2-1.

Each of the 8-digit LED displays is arranged in two separate fields: a 2-digit parameter number, followed by a 6-digit parameter value. Different parameters in the system may be viewed by entering their particular code number into the first field. The current value of that parameter will automatically be displayed in the second field, the parameter value field. Any two parameters may be viewed simultaneously on the display panel.

A keypad lock/unlock feature has been added to make data entry easier and more versatile. Parameters that had previously been set and locked in at the factory will now be programmed in the field. All parameters are protected from inadvertent change except running speeds, angles, Inch and Micro Inch speeds. These are parameters 30 thru 41, 45 and 46. To change any of the protected parameters, unlock the key pad by pressing the following keys in the order listed within five seconds of one another: F1, F2, ENTER. Use the up or down arrow until the word "UNLOCK" is displayed on the DMR. You will have fifteen minutes to change any of the protected parameters. At the end of this timed interval, the DMR will automatically return to the locked configuration. (The LOCK/UNLOCK feature may be disabled by selecting DSBL).

Some parameters must be set up before the press will function properly. These should be set at the initial start-up of the control/press. Some of these are as follows:

- 42 Stop-on-top creep speed angle
- 43 Stop-on-top apply brake angle
- 44 Creed speed-top
- 45 Micro inch speed
- 46 Inch speed
- 81 Stop-on-bottom creep speed angle
- 82 Stop-on-bottom apply brake angle
- 83 Creep speed-bottom

Certain parameter are unique to each press as the mechanical requirements change from one unit to another. The table below lists the set parameters and must be programmed to insure proper press operation.

- 26 Maximum speed
- 27 Line voltage
- 28 Clutch current
- 29 Brake current
- 72 No. of speed feedback periods averaged
- 73 Baud rate

- 78 Gear box ratio
- 79 Tach pulses per revolution
- 80 Pot selector

Parameters are selected for viewing by first selecting either the top or bottom display window (called the active display), and then entering the 2-digit code for that parameter in the parameter number field. The top display windows are selected by pressing the Top button on the keypad, and similarly the bottom display windows are selected by pressing the Bot key. When the display windows become active, the two decimal point LEDs in the parameter number field will light, indicating that it is the active display. The opposite set of display windows will then become inactive (decimal points off), and will continue to display the value of the last parameter number that was entered. Thus, by selecting the top display and entering one code number, and then selecting the bottom display and entering a different code number, it is possible to obtain a continuous readout of any two parameters in the system.

Parameters that may be displayed are broken down into two, categories, non-alterable parameters; and operator-alterable parameters. Non-alterable parameters are for display only, and cannot be modified by the operator. Operator-alterable parameters are variables that are accessible for modification in order to set-up and adjust the system performance. Refer to CES Controller Parameters on the previous page for an explanation of which parameter numbers are for display only and which ones are operator-alterable. All parameters are listed in Table 3-3 and 3-4.

In order to modify an operator-alterable parameter, the code for that particular parameter must be entered into the parameter number field of the active display, which will then display its current value in the parameter value field.

Pressing the Up arrow (↑) button on the keypad will increment that parameter value by one unit for each keystroke. Similarly, pressing the Down arrow button (↓) will decrement the value by one unit per keystroke. Pressing and holding the Up or Down arrow button (↑↓) down for longer than one second will invoke a keystroke auto-repeat function, which will continue to increment or decrement the parameter value for as long as the button is held down. The auto-repeat rate of the button is controlled by the display panel update time parameter and can thus vary from 0.1 to 0.5 second per stroke.

In order to allow for more rapid parameter changes, a fast up/down function is available, which will alter the value by 10 units per increment. This is obtained by first pressing the Asterisk button (\*) and then either the Up arrow (↑) or the Down arrow button to increment or decrement the parameter by 10 units per keystroke.

Fast auto-repeat is also accomplished by pressing the Asterisk button and then pressing and holding one of the arrow buttons down. After releasing the arrow button (↓) for a period longer than one second, the up/down function will revert back to normal speed of operation. A faster up/down function is also available. By first pressing the (#) key and then either the Up or Down arrow button (↑↓), the increment of change will be by 100 units per increment. Any attempt to change a non-alterable display parameter will be ignored.

## OPTIONAL FEATURES

### OPERATING THE PRESS-ON-HOP

This term is used in reference to a press that is basically operating in the single stroke mode. When the press is about to stop, if all limit switches and sensing devices indicate that the mechanical handling equipment is in a GO condition, the press is told not to stop but to continue running.

In the following paragraphs, the word "signal" means the signal that requires the press to continue to run instead of stopping on top.

The signal is a level type rather than an edge type. If the signal is removed before the press reaches the set Creep Angle, the press will go to creep speed and will be commanded for Normal Stop upon reaching the set Stop Angle and the press will in fact Stop-On-Top. This is the equivalent of single stroking the press.

If the signal is removed and returned before the press reaches the Creep Angle, the press will continue to run at the preset Run Speed through the angles where it would otherwise have stopped on top.

If the signal is removed and returned before the press reaches the set Creep Angle, the press will go to the Creep Speed. If the signal is returned before the press reaches the set Stop Angle, the press will continue at the Creep Speed until it reaches the Stop Angle. At this point, the press will continue with the next stroke of the press.

If the signal is removed again before the press reaches the set Stop Angle the press will Stop-On-Top.

In other words; if the signal is present when the set Creep Angle is reached, the press will continue at Run

Speed into the next stroke. This is the equivalent of the continuous mode of operation. If the signal is not present at this point, the press will go to Creep Speed. If after being programmed to Creep Speed, the signal is present when the press reaches the set Stop Angle, the press will return to Run Speed at this point. If it is not present, the press will stop.

The software of the DMR is programmed to function in the above manner as long as the press control sends and removes the signal at the proper times. Also, it is the press control that must make the determination if the press and parts are in fact proper to allow the press to operate On-the-Hop.

### STOP-ON-BOTTOM

A software program has been developed that is helpful in die setting. It is a feature that allows the press to stop-on-the-bottom of the stroke, the place where the die would be clamped or unclamped during die changes.

Some other subtle changes must be accepted if this option is requested. When in the Inch or micro inch mode, the press will always Stop-On-Top. When in the Inch or micro inch modes, 115 volts applied to terminal 318 will result in a Stop-On-Bottom function.

Additional parameters are provided for Stop-On-Bottom Creep Angle, Stop-On-Bottom Apply Brake Angle, and Stop-On-Bottom Creep Speed.

When in the Run mode, 115 volts applied to terminal 318 will result in a continuous operation type of function.

Parameters 42, 43 and 44 will be used in the Run, Inch and Micro Inch modes to effect the Stop-On-Top function.

**Typical DMR Parameter and Fault Number Reference Chart**

**Table 3-3**

PARAMETER NUMBER	PARAMETER	PARAMETER NUMBER	PARAMETER
00	Not Used	72	No. Of Speed Feedback Periods
01	Average Speed Feedback - SPM	73	Serial Interface Baud Rate
02	Speed Reference - SPM	74	Under-speed % Limit
03	Average Speed Error (+/-) - SPM	75	Die Contact Angle
04	Effective Resolver Position	76	Resolver Direction Selection
05	AC Line Voltage - Volts	77	Resolver Offset Angle
06	Not Used	78	Gear Ratio
07	Not Used	79	Pulses per Rev.
08	Clutch Current Feedback - Amps	80	Pot. Selector
09	Brake Current Feedback - Amps		
10	EPROM	<b>FAULT NUMBER</b>	<b>FAULT</b>
11	Part Number	0101	Over-speed
12	Speed at Die Contact Angle - SPM	0202	Loss of Tach
13	Serial Interface Data Received	0208	Clutch Current Delay
14	Analog Speed Reference	0206	Press Movement in Wrong Direction
15	Average Parts per Minute	0207	Loss of Line
16	Clutch Current Timer – SEC	0208	Enable without Clutch On
17	Brake Current Timer - SEC	0209	Cl. Contactor On After Cl. On De-energized
18	CL-BR Coil Cool Down - SEC	0210	Missing Enable
19	Under-speed Timer - SEC	0211	Inch + Micro Inch + Enable
20	Over-speed Timer - SEC	0212	Reverse Command
21	Not Used	0220	Enable Present After Normal Stop
22	Actual Resolver Position	0221	Clutch Contactor Not On in Test Mode
23	Main Program Loop Ctr.	0222	Press Movement in Test Mode
24	Present Pr. Fault Codes	0223	Enable Present in Test Mode
25	Previous Pr. Fault Codes	0224	Stop-On-Top Not Performed
26	Max. Pr. Run Sp. – SPM	0225	Cl. Contactor On Removed w/o Removing
27	Max AC Line Voltage		Enable or During 450 ms Time Delay
28	Max. Cl. Cur. Scaling Factor – Amps	0226	Clutch Contactor On w/o Enable
29	Max. Br. Cur. Scaling Factor – Amps	0227	Enable Before Cool Down Expired
30	Angle 1 - DEG	0228	Creep Sp. Not Reached Before Stop Angle
31	Speed 1 - SPM	0313	Under-speed
32	Angle 2 - DEG	0314	Clutch and Brake Current Overlap
33	Speed 2 - SPM	0315	Clutch Current
34	Angle 3 - DEG	0316	Brake Current
35	Speed 3 - SPM	0317	Inch Change
36	Angle 4 - DEG	0318	Micro Inch Change
37	Speed 4 - SPM	0319	Reverse Change
38	Angle 5 - DEG	0329	Parameter Out of Limits
39	Speed 5 - SPM		
40	Angle 6 - DEG	<b>SIGNALS FOR CHART</b>	
41	Speed 6 - SPM	<b>RECORDER</b>	
42	Stop-On-Top Creep Sp. Angle - DEG	<b>TERMINAL</b>	<b>FUNCTION</b>
43	Stop-On-Top Apply Br. Angle - DEG	337	Common
44	Creep Speed-Top - SPM	338	Speed Reference
45	Micro Inch Speed - SPM	339	Clutch Current
46	Inch Speed - SPM	340	Brake Current
47	Inch Accel Rate – SPM/SEC	341	Speed Feedback
48	Initial Accel Step – SPM		
49	Initial Accel Rate – SPM/SEC	<b>FAULT INDICATOR</b>	<b>FAULT</b>
50	Run Accel Rate 1 – SPM/SEC	NUMBER	Run Signal is Present
51	Run Accel Rate 2 – SPM/SEC	0	Push Reset
52	Run Accel Rate 3 – SPM/SEC	1	External
53	Run Accel Delta 1 – SPM/SEC	2	Brake Free Wheel
54	Run Accel Delta 2 – SPM/SEC	3	Low Line
55	Run Decel Rate 1 – SPM/SEC	4	Brake Over-current
56	Run Decel Rate 2 - SPM/SEC	5	Clutch Free Wheel
57	Run Decel Rate 3 - SPM/SEC	6	Line/Microprocessor
58	Run Decel Delta 1 – SPM/SEC	7	Clutch Over-current
59	Run Decel Delta 2 – SPM/SEC		
60	Test Mode		
61	Clutch Test Mode		
62	Brake Test Mode		
63	Clear Faults		
64	Cl. Cur. On too Long Timer - SEC		
65	Br. Cur. On too Long Timer - SEC		
66	Cl/Br Coil Cool Down Timer - SEC		
67	Under-speed Timer - SEC		
68	Over-speed Timer - SEC		
69	% Over-speed - %		
70	Wrong Direction Limit - DEG		
71	Display Update Time - SEC		

**Special DMR Parameter and Fault Number Reference Chart for DMR with Stop-On-Bottom Feature Table 3-4**

PARAMETER NUMBER	PARAMETER	PARAMETER NUMBER	PARAMETER
00	Not Used	72	No. Of Speed Feedback Periods
01	Average Speed Feedback - SPM	73	Serial Interface Baud Rate
02	Speed Reference - SPM	74	Under-speed % Limit
03	Average Speed Error (+/-) - SPM	75	Die Contact Angle
04	Effective Resolver Position	76	Resolver Direction Selection
05	AC Line Voltage - Volts	77	Resolver Offset Angle
06	Not Used	78	Gear Ratio
07	Not Used	79	Pulses per Rev.
08	Clutch Current Feedback - Amps	80	Pot. Selector
09	Brake Current Feedback - Amps	81	Stop-On-Bottom Creep Speed Angle - DEG
10	EPROM	82	Stop-On- Bottom Apply Brake Angle - DEG
11	Part Number	83	Creep Speed-Bottom - SPM
12	Speed at Die Contact Angle - SPM		FAULT
13	Serial Interface Data Received	0101	Over-speed
14	Analog Speed Reference	0202	Loss of Tach
15	Average Parts per Minute	0208	Clutch Current Delay
16	Clutch Current Timer - SEC	0206	Press Movement in Wrong Direction
17	Brake Current Timer - SEC	0207	Loss of Line
18	CL-BR Coil Cool Down - SEC	0208	Enable without Clutch On
19	Under-speed Timer - SEC	0209	Cl. Contactor On After Cl. On De-energized
20	Over-speed Timer - SEC	0210	Missing Enable
21	Not Used	0211	Inch + Micro Inch + Enable
22	Actual Resolver Position	0212	Reverse Command
23	Main Program Loop Ctr.	0220	Enable Present After Normal Stop
24	Present Pr. Fault Codes	0221	Clutch Contactor Not On in Test Mode
25	Previous Pr. Fault Codes	0222	Press Movement in Test Mode
26	Max. Pr. Run Sp. – SPM	0223	Enable Present in Test Mode
27	Max AC Line Voltage	0224	Stop-On-Top Not Performed
28	Max. Cl. Cur. Scaling Factor – Amps	0225	Cl. Contactor On Removed w/o Removing
29	Max. Br. Cur. Scaling Factor – Amps		Enable or During 450 ms Time Delay
30	Angle 1 - DEG	0226	Clutch Contactor On w/o Enable
31	Speed 1 - SPM	0227	Enable Before Cool Down Expired
32	Angle 2 - DEG	0228	Creep Sp. Not Reached Before Stop Angle
33	Speed 2 - SPM	0313	Under-speed
34	Angle 3 - DEG	0314	Clutch and Brake Current Overlap
35	Speed 3 - SPM	0315	Clutch Current
36	Angle 4 - DEG	0316	Brake Current
37	Speed 4 - SPM	0317	Inch Change
38	Angle 5 - DEG	0318	Micro Inch Change
39	Speed 5 - SPM	0319	Reverse Change
40	Angle 6 - DEG	0329	Parameter Out of Limits
41	Speed 6 - SPM		SIGNALS FOR CHART
42	Stop-On-Top Creep Sp. Angle - DEG		RECORDER
43	Stop-On-Top Apply Br. Angle - DEG		TERMINAL
44	Creep Speed-Top - SPM	337	Common
45	Micro Inch Speed - SPM	338	Speed Reference
46	Inch Speed - SPM	339	Clutch Current
47	Inch Accel Rate – SPM/SEC	340	Brake Current
48	Initial Accel Step – SPM	341	Speed Feedback
49	Initial Accel Rate – SPM/SEC		FAULT INDICATOR
50	Run Accel Rate 1 – SPM/SEC		NUMBER
51	Run Accel Rate 2 – SPM/SEC	-	FAULT
52	Run Accel Rate 3 – SPM/SEC	0	Run Signal is Present
53	Run Accel Delta 1 – SPM/SEC	1	Push Reset
54	Run Accel Delta 2 – SPM/SEC	2	External
55	Run Decel Rate 1 – SPM/SEC	3	Brake Free Wheel
56	Run Decel Rate 2 - SPM/SEC	4	Low Line
57	Run Decel Rate 3 - SPM/SEC	5	Brake Over-current
58	Run Decel Delta 1 – SPM/SEC	6	Clutch Free Wheel
59	Run Decel Delta 2 – SPM/SEC	7	Line/Microprocessor
60	Test Mode		Clutch Over-current
61	Clutch Test Mode		
62	Brake Test Mode		
63	Clear Faults		
64	Cl. Cur. On too Long Timer - SEC		
65	Br. Cur. On too Long Timer - SEC		
66	Cl/Br Coil Cool Down Timer - SEC		
67	Under-speed Timer - SEC		
68	Over-speed Timer - SEC		
69	% Over-speed - %		
70	Wrong Direction Limit - DEG		
71	Display Update Time - SEC		

## START-UP AND ADJUSTMENT

This controller replaces the present Dynamatic Analog CES Press Control in all aspects and adds numerous diagnostic features. This design replaces discrete analog and digital control circuitry with microprocessor based operation where advantageous.

### POWER CONVERSION

The CES Press Control provides control for the full range of Dynamatic press drives. The power conversion circuitry operates from 480 volts (+10%, -15 %) input and provides a maximum of 850 volts dc coil excitation voltage. The following maximum current levels are available:

1. Clutch Excitation - provides 180 amps at 70% duty cycle.
2. Brake Excitation - provides 90amps at 30% duty cycle.

Refer to the power schematic for your press drive for the following discussion. Both the clutch and the brake power-sections consist of rectifier circuits to convert the ac line power to dc power. Each circuit employs a full wave bridge rectifier consisting of six SCRs and resistor-capacitor networks for suppression. There is a clutch contactor and a brake contactor for electromechanically disconnecting the clutch and brake respectively. There are three line fuses and a circuit breaker for over-current protection. An autotransformer steps the 480 volt line voltage up to 600 volts for the required forcing voltage. The clutch gate driver and brake gate driver printed circuit boards provide isolation and amplification of the SCR firing pulses.

### PRESS SPEED CONTROL

The press control provides closed loop speed control operation with inner current loops on both the clutch and brake. It provides adjustable acceleration and deceleration. The reference data is modified by a press angle measuring and control circuit function that will change the reference at adjustable angles.

The logic circuitry is located on printed circuit board assembly number 15-822-1, through 15-822-10, depending on the size of the mechanical unit. This board has circuitry that performs the following functions:

1. Compares the reference voltage to the speed velocity voltage. The difference is used to fire the SCRs that provide the power required to maintain the set speed.
2. Limits the clutch current to a value equal to the rating of the mechanical unit.
3. Limits the brake current to a value equal to the rating of the mechanical unit.
4. Provides adjustable velocity damping to the clutch circuitry.
5. Provides adjustable velocity damping to the brake circuitry.

6. Provides clutch "free wheel" command signals to prevent damage to the clutch SCRs.
7. Provides brake "free wheel" command signals to prevent damage to the brake SCRs
8. Control amplifiers that compare the clutch and brake current reference signals to current feedback signals.
9. Phase shifter microprocessors in the clutch and brake circuit, which control the firing angles of the clutch and brake amplifier SCRs.

### ANGLE MEASURING AND CONTROL CIRCUITRY

The CES press control provides a means of measuring press angles by utilizing a position resolver mounted on the output press gearing (the crank shaft of the slide). The position information is used to set a reference profile based on stored data of up to 6 angles and 6 predetermined speeds.

The control digital board is a microprocessor-based solid state control system capable of receiving data from the press control, storing it, and then using it to provide reference speed signals to the CES control.

### START-UP PROCEDURE

Use a digital multimeter (such as a Fluke 8010A) with 1% or better accuracy for all measurements required during start-up.

1. Turn the circuit breaker to the OFF position. Turn all incoming signals OFF.
  - a. Check all terminal screws for tightness.
  - b. Make certain that All plugs are properly seated.
  - c. Check for loose connections.
  - d. Set potentiometers as follows.
    - 1) Clutch Velocity Damping 50%.
    - 2) Clutch Current Damping 50%.
    - 3) Brake Velocity Damping 50%.
    - 4) Brake Current Damping 50%.
  - e. Install a jumper from 300 to 302. This will allow 115 volts to be present in the CES press control when the circuit breaker is placed in the ON position.
2. Turn the circuit breaker to the ON position.
  - a. Check for the presence of 115 volts on the secondary of the control transformer.
  - b. Check the power supplies for their voltages (+/- 0.5%) of -12 VDC, +24 VDC, +12 VDC & +5 VDC.
  - c. Check the line voltages LA-LB-LC for the presence of 600 volts, +/- 10%.

3A. Older controls have two EPROM's provided with each control.

a. One EPROM protects certain parameters that are adjustable from the keypad from accidental changes. These parameters are:

- 26 Maximum Speed
- 27 Line Voltage
- 28 Clutch Current
- 29 Brake Current
- 72 Number of Speed Feedback Periods
- 73 Baud Rate
- 78 Gear Box Ratio
- 79 Tach Pulses Per Revolution
- 80 Potentiometer Selector

b. One EPROM allows the above parameters to be changed in the field if necessary. Each of the above parameters should be verified as correct for a particular installation and changed if found to be incorrect.

3B. Newer controls have but one EPROM that protects all changeable parameters except those from 30 through 41, 45 and 46. To change any of the protected parameters the keypad must first be unlocked using the password provided in separate instructions.

4. Note that resolver must be connected when in test mode or you will get a 222 fault. Enter the test mode of the DMR by proceeding as follows:

a. Padlock the main motor of the press in the OFF position.  
b. Turn the Press Control OFF.  
c. On the DMR keypad, enter the test mode as follows:

- 1) Press the Top key. This will activate the top row of the display.
- 2) Press the "6" and the "0" keys for parameter No. 60.
- 3) "60" and "OFF" will appear in the top row of display.
- 4) Press the up arrow (↑)
- 5) "60" and "ON" will appear in the top row of display, indicating the test mode has been activated.

d. Turn the CES circuit breaker to the OFF position.

e. Remove the following incoming leads from the terminal block and tape ends: 320, 321, 334, 302, 319 and 348.

f. Install the following jumpers: 302 to 320, 301 to 334 (to put 115 volts across the clutch contactor ON signal), 15 to 16 (across CR2) and 26 to 27 (across the TD contact).

g. Turn the CES circuit breaker to the ON position.

h. The DMR will remember that it is in the test mode. "60\_\_\_\_\_On" will reappear in the top row of display.

i. The test mode will be indicated by the "Test" LED on the keypad and display board.

5. Enter the clutch test mode.

a. While in the test mode, the clutch test mode can be entered by setting the clutch test mode parameter No. 61 to "ON". Proceed as follows:

- 1) Press the Bot key. This will activate the bottom row of the display.
- 2) Press the "6" and the "1" keys for parameter No. 61.
- 3) "61 \_\_c1 OFF" will appear in the bottom row of the display
- 4) Press the up arrow (↑).
- 5) "61 \_\_c1 ON" will appear in the bottom row, indicating that the clutch test mode has been activated.

b. The clutch current will go to its maximum value as set by the Current Limit potentiometer.

c. Verify that the Clutch Current Limit potentiometer limits the clutch current to the proper value for the size of the mechanical unit. Adjust the Current Limit potentiometer only if necessary for the proper amps, +/-1amp.

d. To return the current to zero:

- 1) Press the down arrow (↓).
- 2) "61\_\_cl\_\_OFF" will appear in the bottom row of the display.

WARNING: Note that if the clutch current is left ON for more than the setting of the Clutch Current On Too Long Fault, a clutch current fault will result and it will take ten minutes before the fault can be reset. The clutch current fault is adjustable from 3 to 20 seconds.

e. Leave the clutch test mode by entering the brake test mode.

6. Enter the brake test mode.

a. While in the clutch test OFF mode set the brake test mode parameter No. 62 to ON. Proceed as follows:

- 1) Press the "6" and the "2" keys for parameter No. 62.
- 2) "62 \_\_\_br\_\_\_ OFF" will appear in the bottom row of the display.
- 3) Press the up arrow (↑).
- 4) "62 \_\_\_br\_\_\_ ON" will appear in the bottom row, indicating that the brake test mode has been activated

b. The brake current will go to its maximum value, as set by the Brake Current Limit potentiometer.

c. Verify that the Brake Current Limit potentiometer limits the brake current to the proper value for

the size of the mechanical unit, +/-1 amp. Adjust the Brake Current Limit potentiometer only if necessary for the proper Amps.

- d. To return the brake current to zero:
  - 1) Press the down arrow (↓).
  - 2) "62 \_\_\_br\_\_\_ OFF" will appear in the bottom row of the display.

WARNING: Note that if the brake current is left ON for more than the setting of the Brake Current On Too Long Fault, a brake current fault will result and it will take ten minutes before the fault can be reset

7. Note the following test mode faults:
  - a. Receiving an enable in the test mode will result in an enable in the test mode fault.
  - b. Sensing press movement in the test mode will initiate a press movement in the test mode fault.
8. Turn the CES circuit breaker OFF.
  - a. Remove all of the jumpers added during this set-up. The main motor should remain OFF.
9. Turn the CES circuit breaker ON.
  - a. The DMR will be in the test mode.
  - b. To exit the test mode:
    - 1) Press the Top key. This will activate the top row of the display.
    - 2) "60 ON" will appear in the top row of the display.
    - 3) Press the down arrow.
    - 4) "60 OFF" will appear in the top row of the display.
  - c. Send the following signals from the press control to the CES controller. Remove the signal after making the prescribed check. When faults are simulated, send the fault reset signal from the press control to reset the CES controller.
    - 1) Inch - Check for presence of LED on I/O board and on the keypad and display board.
    - 2) Micro Inch - Check for presence of LED on I/O board and on the keypad and display board.
    - 3) Reverse – Check for presence of LED on I/O board and on the keypad and display board.
    - 4) Stop-On-Top - Check for presence of LED on the I/O board
    - 5) Clutch Contactor ON and Enable - Check for presence of comparable LEDs on the I/O board. Since the motor is not running, an under-speed fault will result and a stop-on-top fault will be generated. Check this LED on the I/O board. Since the press is not

rotating, it will not get to the creep angle or the stop angle; therefore, a stop now fault will be generated. Check this LED on the I/O board.

- 6) Send the clutch contactor ON signal without the enable signal. A stop now fault will be generated.
  - 7) Send the enable signal without the clutch contactor ON signal. A stop now fault will be generated.
10. Run the Press in the Inch Mode.
    - a. Set the DMR parameter to the inch mode.
    - b. Enter five strokes per minutes
    - c. Set the DMR parameter to inch accel rate, parameter No. 47. Enter the proper rate.
    - d. Jog the press through one or more strokes, checking clearances, mechanical interference, etc.
    - e. Use the Inch pushbutton for the jog function.
  11. Resolver Adjustment
    - a. Select the top display area and select parameter No. 04.
    - b. Select the bottom display area and select parameter No. 77. Using the Down arrow set to zero degrees (0°).
    - c. In the bottom area, select parameter No. 76 and set for forward direction. Inch the press. If a 206 fault results, change parameter to REV. If no fault, proceed to the next step.
    - d. Position the press to some known angle, typically Bottom Dead Center (180°).
    - e. Select parameter No. 77 in the bottom area. Using up or down arrows, adjust this parameter until parameter No. 04 reads the position of the press. This completes the setup of the resolver.
  12. Operate the Press in the Run Mode.
    - a. Set the DMR to the run parameter.
    - b. Enter a profile of run speeds:
      - 1) Enter degrees for six angles, parameters 30, 32, 34, 36, 38 and 40. If an angle is not used, set it to the "skip angle" this is 360 degrees.
      - 2) Enter strokes-per-minute for six speeds, parameters 31, 33, 35, 37, 39 and 41.
      - 3) Enter Operating Accel Rates, Nos. 1, 2 and 3, parameters 50, 51 and 52.
      - 4) Enter Accel Rate Delta SPM, Nos. 1 and 2, parameters 53 and 54.
      - 5) Enter Operating Decel Rates, Nos. 1, 2 and 3, parameters 55, 56 and 57.
      - 6) Enter Decel Rate Delta SPM, Nos. 1 and 2, parameters 58 and 59.
      - 7) Enter Initial Value of Linear Accel Ramp, parameter 48.



- 8) Enter Creep Angle, parameter 42.
- 9) Enter Stop Angle, parameter 43.
- 10) Enter Creep Speed, parameter 44.
- 11) Enter Max Speed, parameter 26.
- 12) Enter Initial Accel Rate, parameter 49.
- 13) Enter the Wrong Direction Limit, parameter 70.

- c. Run the press through several cycles.
- d. Use the stop-on-top function to stop the press. Readjust the creep speed, creep angle, and stop angle, if necessary, to attain the proper stopping on top.

13. Run the Press in the Micro Inch Mode.

- a. Enter the Micro Inch Speed, parameter 45.
- b. Jog the press through one or more strokes.
- c. Use the Inch pushbutton for this jog function.

14. Check the Remaining Faults.

**APPROXIMATE PARAMETER SETTINGS**

Approximate parameter settings, which are furnished for trial only, are indicated in Table 4-1. Actual settings will be determined during the press set-up. If, for security reasons, the customer removes the ribbon cable connecting the keypad to the DMR, care must be exercised in removing the power to the DMR when removing or replacing the cable. Otherwise, damage may result to the unit.

A resume of serial interface commands from the press control to the DMR is as follows:

- AA Accept downloaded parameters that follow.
- BB Send fault codes
- CC Send monitor data.
- DD Begin using parameters down loaded with last AA commands
- EE Echo back last AA parameters.

**Typical Parameter Settings**

**Table 4-1**

Parameter Number	Value
26	Max press speed
27	480.00
28	Same as CL Meter
29	Same as BR Meter
30	180.0
31	20.0*
32	90.0
83	10.0
34	170.0
35	20.0
36	360.0
37	20.0
38	360.0
39	20.0
40	360.0
41	20.0
42	300.0
43	354.0
44	5.0
45	5.0
46	10.0
47	100.0
48	3.0
49	100.0
50	100.0
51	100.0
52	100.0
58	5.0
54	5.0
55	100.0
56	100.0
57	100.0
58	5.5
59	5.5
60	Off
61	Off
62	Off
63	Clear
64	10.0
65	10.0
66	300.0
67	2.0
68	2.0
69	10.0
70	3.0
71	.1
72	1.0
73	9600.0
74	10.0
75	120.0
76	See resolver adjustments under Start-Up Section
77	See resolver adjustments under Start-Up Section
78	See press specifications
79	See speed reference section
80	Self Explanatory
81	150.0
82	170.0
83	3.0

\*NOTE: Parameter No. 31 will be altered by either the Trim Speed pot or the Manual Speed pot, depending on which is used.

## MAINTENANCE AND TROUBLE SHOOTING

### MAINTENANCE

Very little maintenance is required to keep the CES stamping press controller in service. Periodically, we suggest that you check the controller to make sure all terminal screws and other connections are tight. Look for signs of trouble, such as burn spots on the boards, loose parts, worn out switches, pushbuttons or LEDs, and any other abnormal condition. Correct any deficiency found. If you have a question, call DSI/Dynamatic at 1-800-548-2169, fax 262-554-7041 or E-mail sales@drivesourceusa.com.

The relays in the controller have a definite life, as do potentiometers and switches. They are designed for many years of average use; however, if your operation calls for more frequent switching, we suggest you stock replacements based on your type of operation. If you need help in deciding which parts to stock, our Renewal Parts Department will help you. A Master Parts List, with recommended spare parts noted, is included on page 5-2 for your specific controller. This is based on average conditions.

### TROUBLESHOOTING

The possibility of a component failure or other problem always exists. This section of the manual is provided to assist you in finding the fault and expediting the repair. Our design philosophy is based on assembly replacement. Trying to find a component failure on a printed circuit board is not economical when you compare the cost of labor and down time with the cost of a replacement PCB assembly. Therefore, this manual limits troubleshooting to the sub-assembly level. Always check the obvious. Are the plug and switches in the right position and the power ON?

**CAUTION:** Turn ac power to the Motor and controller OFF before making tests, except when voltage measurements are necessary. Only qualified personnel acquainted with proper safety procedures should service this equipment.

If the press drive will not run, we suggest you complete the following tests to check out the controller operation.

With ac power removed, connect your multimeter set on 500 VAC range. Measure controller terminals 1L1, 1L2 and 1L3. With power OFF you should read zero volts. Do not proceed until a zero reading is obtained. Then pull fuses FU1, FU2 and FU3 (on the main PCB assembly) and check for blown fuses. Replace if required and re-install FU1, FU2 and FU3 in the controller.

If a fuse blows on a cold start, there may be a short or ground in the coil lead wires. Disconnect both leads at the controller terminal strip and check the resistance of the coil and resistance to ground. Check the drive nameplate or contact the Field Service Department at

the factory for the coil resistance. Resistance to ground should be about 20 megohms. When using a megger, make sure both coil leads are disconnected from the controller. Do not megger any portion of the controller.

If the drive is erratic or hunts, we suggest you check for loose connections, proper brush seating, a good slip ring surface and load pulsations that can reflect erratic load to the controller. If no external cause is found, replace the main PCB assembly.

**Generator:** The approximate generator coil resistance for the 37 series of press drive mechanical units to 94 ohms and for the 49 series is 22 ohms.

There are two generator coils on each mechanical unit. If one in ever lost, the other one may be connected in its place. The connection diagram calls for both generator coils to be connected to the terminal block in the control enclosure. Therefore, the second coil leads should be readily available should a failure occur.

### INTERCHANGING ASSEMBLIES

The DMR assemblies (15-820-\*) are similar to one another. The EPROM's are programmed differently and the Absolute Position Resolver board on the DMR assembly may be a 15-779-112 or a 15-779-113. It will vary depending on whether the power to the resolver is provided by Dynamatic (15-779-113) or is provided by others (15-779-112). The only difference is the presence or absence of the W7 jumper on this board. If Dynamatic is providing the power, it is required. If not, it must be removed with this in mind one DMR assembly may be used as a back up for more than one press.

When making any substitution of the DMR assembly, the following items must be checked:

1. The contact that calls for either single stroke or continuous running of the press must be closed to cause the press to run continuous and open to cause the press to run in single stroke. That way an open wire or a poor contact connection will cause the press to single stroke.
2. The EPROM located in the DMR assembly has several parameters that are programmable. These must be properly programmed before operating the press after changing DMR's. Therefore, before removing the defective DMR, record all of the variable parameters. It is advisable to record this data when the press is first put into operation for, depending on what the problem is in the defective DMR, this data may be lost when the DMR first becomes defective.
3. In the typical DMR the following parameters must be programmed:
  - 26 Maximum Speed
  - 27 Line Voltage
  - 28 Clutch Current

- 29 Brake Current
- 72 No. of Speed Feedback Periods Averaged
- 73 Baud Rate
- 78 Gear Box Ratio
- 79 Tach Pulses Per Revolution
- 80 Pot Selector

In some controls the following additional parameters must be programmed:

- 81 Stop-On-Bottom Creep Speed Angle
- 82 Stop-On-Bottom Apply Brake Angle
- 83 Creep Speed-Bottom

4. If the parameter information that is protected is lost, contact the factory, it may be available for your particular press.

The logic PCB assemblies (15-822-\*) are identical except for R5 and R131. Therefore, one assembly can be used as a backup for different -\* numbers in case of a failure provided R5 and R131 are changed according to the chart that follows: (Note the 15-822-\* replaces the older 15-815-\* assembly).

PCB ASSEMBLY NUMBER	RESISTANCE (Ohms)	
	R5	R131
15-822-1	90.9 K	90.9 K
15-822-2	48.7 K	48.7 K
15-822-3	124.0 K	124.0 K
15-822-4	71.5 K	124.0 K
15-822-5	115.0 K	115.0 K
15-822-6	28.7 K	28.7 K
15-822-7	60.4 K	60.4 K
15-822-8	84.5 K	84.5 K
15-822-9	124.0 K	84.5 K
15-822-10	84.5 K	84.5 K

### RENEWAL PARTS AND SERVICE

Some renewal parts for the CES Stamping Press Controller are stocked at the factory. We suggest you stock renewal parts to minimize down time. You alone can evaluate the cost of down time compared to the cost of stocking spares. If you need help in establishing an appropriate list and stock levels, contact your local sales office.

Warranty controller failure will be handled by replacement. Technical assistance is available over the telephone, and field service engineers are available for start-up, troubleshooting and training. You may inquire about rates and scheduling from the factory.

The company maintains a Repair Service Department and work is done on a time and material basis. All replacement boards will carry a new factory warranty.

Refer to Tables 2-1 and 2-2 for DMR assemblies and scaling PCBs.

### List of Spare Parts Common to All CES/DR Controls

Recommended Qty.	Dynamatic Part Number	Description	Symbol
1	15-242-57	CES logic interface indicator PCB assembly	
1	15-358-502	Control station pot assembly	
1	15-565-27	CES press drive clutch gate driver, 600 V	
1	16-565-28	CES press drive brake gate driver, 600 V	
3	15-825-1	CES press drive suppressor	
1	15-6502-3001	Modified 15-6502-3000 PCB assembly	
1	15-6504-6	Power supply assembly	
3	23-298-180	Capacitor, 18 mfd. 660 VAC, w/mtg. brackets	C3, 4, 5
3	32-48-4591	Fuse, 4.5 A, 250 V	FU4
3	32-101-1591	Fuse, time delay, 1.5 A, 500 V	FU5, FU6
6	32-105-121	Fuse, 125 A, 600 V	FU1, 2, 3
3	33-1-101	RF filter, 100 ohm resistor, 0.25 mfd. capacitor	RC
1	37-162-1104	Voltmeter assembly, 1-10 VDC; to specify scale	MTR1, 2, 3
1	53-133-0	Relay, 4dpt, 115 VAC, 50/60 Hz.	CR2
1	53-289-0	Relay 4p, 120/110 VAC, 50/60 Hz.	CR1
1	53-407-1	Relay, time delay	TD
1	53-534-1	Contactors, Size 2	BR
1	53-570-4	Contactors, Size 3	CL
2	55-396-661	Varistor, 660 V rms	Q3, 4
2	55-422-1	Input module, 90 to 140 VAC	For I/O
.2	55-422-7	Output module, 12 to 140 VAC	For I/O
12	55-589-182	Double SCR package, 1800 V, 90 A	SCR1-12
1	64-175-14	Transformer, 500 VAD, 50/60 Hz, 230/460 V Primary	T1



**DRIVE SOURCE INTERNATIONAL INC.**

**7900 Durand Avenue, P.O. Box 0361**

**Sturtevant, WI USA 53177**

**Toll Free: (800) 548-2169**

**Phone: (262) 554-7977 - Fax: (262) 554- 7041**

**Email: [sales@drivesourceusa.com](mailto:sales@drivesourceusa.com)**

**24 Hours Service: (262) 499-0437**

*Application Engineering ✧ Quality Products ✧ Total Solution*